NO. F087-880

ISSUED: JUL. 9, 2012

REVISED: APR. 25, 2014



**HOSHIZAKI
MODULAR ICE MAKER**

**MODEL FM-300AKE-HC
 FM-300AKE-HCN
 FM-480AKE-HC
 FM-480AKE-HCN**

SERVICE MANUAL

CONTENTS

PAGE

I. SPECIFICATIONS -----	1
1. DIMENSIONS/SPECIFICATIONS -----	1
[a] FM-300AKE-HC (Auxiliary code: D-0 or earlier)-----	1
[b] FM-300AKE-HC (Auxiliary code: D-1 or later) -----	2
[c] FM-300AKE-HCN (Auxiliary code: D-0 or earlier)-----	3
[d] FM-300AKE-HCN (Auxiliary code: D-1 or later) -----	4
[e] FM-480AKE-HC (Auxiliary code: D-0 or earlier) -----	5
[f] FM-480AKE-HC (Auxiliary code: D-1 or later) -----	6
[g] FM-480AKE-HCN (Auxiliary code: D-0 or earlier)-----	7
[h] FM-480AKE-HCN (Auxiliary code: D-1 or later) -----	8
2. CONSTRUCTION -----	9
[a] FM-300AKE-HC(N) (Auxiliary code: D-0 or earlier)-----	9
[b] FM-480AKE-HC(N) (Auxiliary code: D-0 or earlier)-----	10
[c] FM-300, 480AKE-HC(N) (Auxiliary code: D-1 or earlier) -----	11
II. MAINTENANCE AND CLEANING INSTRUCTIONS-----	12
1. EXTRUDING HEAD (UPPER BEARING), HOUSING (LOWER BEARING) -----	12
2. MECHANICAL SEAL -----	12
3. GEAR MOTOR-----	13
4. CONDENSER (AIR-COOLED MODEL ONLY) -----	13
5. AIR FILTER (AIR-COOLED MODEL ONLY) -----	13
6. CONTROL WATER VALVE -----	14
7. CLEANING OF WATER SYSTEM -----	15
III. TECHNICAL INFORMATION-----	17
1. WATER CIRCUIT AND REFRIGERANT CIRCUIT -----	17
2. WIRING DIAGRAM -----	18
[a] WIRING DIAGRAM-----	18
[b] CONTROL BOX LAYOUT -----	22
3. ICEMAKING MECHANISM -----	23
[a] EVAPORATOR (CASING)-----	24
[b] AUGER -----	24
[c] EXTRUDING HEAD (BEARING)-----	24
[d] HOUSING-----	24
[e] MECHANICAL SEAL-----	24
[f] COUPLING (SPLINE JOINT) -----	24
[g] GEAR MOTOR -----	24
[h] BELT HEATER -----	25
[i] REMOVABLE FLANGE -----	25
[j] SEALING BOLT -----	25
[k] BIN CONTROL SWITCH (Auxiliary code: D-0 or earlier) -----	26
[l] BIN CONTROL SWITCH (Auxiliary code: D-1 or later)-----	26
[m] CHUTE SWITCH (Auxiliary code: D-0 or earlier)-----	28
[n] SPOUT, SPOUT COVER (Auxiliary code: D-0 or earlier)-----	28
4. ELECTRIC CIRCUIT -----	29
[a] BASIC OPERATION -----	29

[b] TIMING CHART -----	30
5. OPERATION BOARD -----	31
[a] OPERATION BUTTONS -----	31
[b] SETTING MODEL NUMBER -----	31
[c] DISPLAYING COMPRESSOR OPERATING HOURS, CYCLE TIME, MODEL NUMBER AND SOFTWARE VERSION -----	32
[d] DISPLAYING ERROR LOG -----	34
[e] RESETTING ERROR LOG -----	35
[f] RESETTING COMPRESSOR OPERATING HOURS -----	35
[g] REDUCING COMPRESSOR STARTING TIME -----	36
6. PROTECTORS -----	36
[a] INDICATION -----	36
7. ERROR CODES -----	37
8. PERFORMANCE DATA -----	31
[a] FM-300AKE-HC -----	39
[b] FM-300AKE-HCN -----	40
[c] FM-480AKE-HC -----	41
[d] FM-480AKE-HCN -----	42
IV. SERVICE DIAGNOSIS -----	43
1. NO ICE PRODUCTION -----	43
2. LOW ICE PRODUCTION -----	45
3. OTHERS -----	45
V. REMOVAL AND REPLACEMENT OF COMPONENTS -----	47
1. REFRIGERATION CIRCUIT -----	47
[a] APPLICABLE PARTS -----	47
2. EVAPORATOR ASSEMBLY -----	47
3. CONTROL WATER VALVE -----	49
4. FLUSH WATER VALVE -----	49
5. CONTROLLER BOARD -----	50
[a] MODIFICATION -----	50
[b] REPLACEMENT -----	50

I. SPECIFICATIONS

1. DIMENSIONS/SPECIFICATIONS

[a] FM-300AKE-HC (Auxiliary code: D-0 or earlier)

ITEM	HOSHIZAKI FLAKE ICE MAKER
MODEL	FM-300AKE-HC
POWER SUPPLY	1 Phase 220V-240V 50Hz Capacity: 1.53kVA (6.4A)
AMPERAGE	4.8A Starting: 20A
ELECTRIC CONSUMPTION	900W (Power Factor: 82.5%)
ICE PRODUCTION PER 24h	Approx. 300kg (Ambient Temp. 10°C, Water Temp. 10°C) Approx. 250kg (Ambient Temp. 21°C, Water Temp. 15°C) Approx. 205kg (Ambient Temp. 32°C, Water Temp. 21°C)
SHAPE OF ICE	Flake
MAX. STORAGE CAPACITY	Not Applicable
WATER CONSUMPTION PER 24h	Approx. 0.300m ³ (Ambient Temp. 10°C, Water Temp. 10°C) Approx. 0.250m ³ (Ambient Temp. 21°C, Water Temp. 15°C) Approx. 0.205m ³ (Ambient Temp. 32°C, Water Temp. 21°C)
OUTSIDE DIMENSIONS	560(W) x 700(D) x 780mm(H)
HEAT REJECTION	1840W (Ambient temp. 32°C, Water Temp. 21°C)
CABINET	Stainless Steel, Galvanized Steel (Rear)
ICE MAKING SYSTEM	Thin ice forming inside Cylinder (Flake Ice)
WATER SUPPLY SYSTEM	Direct Connection to Water Main, Inlet: G3/4 (Rear)
DRAIN SYSTEM	Outlet: R3/4 (Rear)
COMPRESSOR	Hermetic
CONDENSER	Spiral Tube Type, Air-cooled
EVAPORATOR	Tube coiled around Cylinder (Solder Plated)
REFRIGERANT	R290
BIN CONTROL	Actuator and Reed Switch (Time delay controlled)
ICEMAKING WATER CONTROL	Float Switch and Solenoid Valve
ELECTRICAL CIRCUT PROTECTION	Circuit Breaker, Earth Wire
OVERHEAT CIRCUT PROTECTION	Compressor Infrared Thermistal (Auto-ress), Pressure Switch (Auto-ress)
MECHANISM PROTECTION	Micro Switch (Manual-reset)
INTERLOCK	Shutdown by Microprocessor (Manual-reset)
WEIGHT	Net: 81kg (Gross: 88kg)
PACKAGE	Carton 671(W) x 820(D) x 971mm(H)
ACCESSORIES	Mounting Bracket, Installation Kit
OPERATING CONDITIONS	Water Supply Pressure: 0.05-0.8MPa (0.5-8bar) Voltage Range: Rated Voltage ± 6%

*We reserve the right to make changes in specifications and design without prior notice.

1. Install the ice maker properly in accordance with the instructions on location, water supply/drain connections and electrical connections stated in the instruction and installation manuals provided.
2. The ice production depends on the ambient and water temperatures. Refer to the instruction manual.
3. Product Code: F088

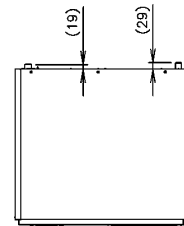
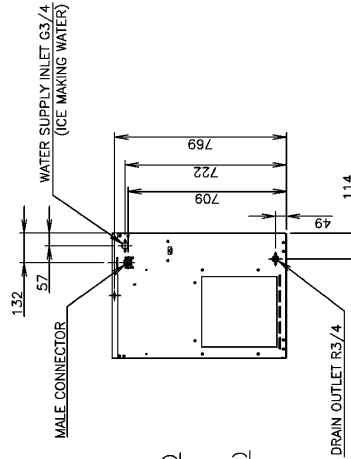
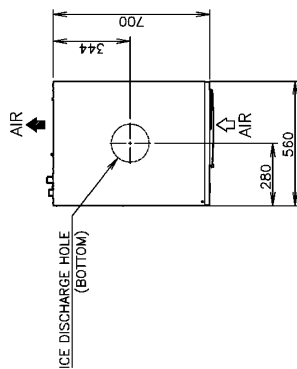

[b] FM-300AKE-HC (Auxiliary code: D-1 or later)

ITEM	HOSHIZAKI FLAKE ICE MAKER
MODEL	FM-300AKE-HC
POWER SUPPLY	1 Phase 220V-240V 50Hz Capacity: 1.53kVA (6.4A)
AMPERAGE	4.8A Starting: 20A
ELECTRIC CONSUMPTION	900W (Power Factor: 82.5%)
ICE PRODUCTION PER 24h	Approx.300kg (Ambient Temp. 10°C, Water Temp. 10°C) Approx.250kg (Ambient Temp. 21°C, Water Temp. 15°C) Approx.205kg (Ambient Temp. 32°C, Water Temp. 21°C)
SHAPE OF ICE	Flake
WATER STORAGE CAPACITY	Not Applicable
WATER CONSUMPTION PER 24h	Approx.0.300cm ³ (Ambient Temp. 10°C, Water Temp. 10°C) Approx.0.250cm ³ (Ambient Temp. 21°C, Water Temp. 15°C) Approx.0.205cm ³ (Ambient Temp. 32°C, Water Temp. 21°C)
OUTSIDE DIMENSIONS	560(W) x 700(D) x 780mm(H)
HEAT REJECTION	1840W(Ambient temp.32°C,Water temp.21°C)
CABINET	Stainless Steel, Galvanized Steel (Rear)
ICE MAKING SYSTEM	Thin ice forming inside Cylinder (Flake Ice)
WATER SUPPLY SYSTEM	Direct Connection to Water Main, Inlet: G3/4 (Rear)
DRAIN SYSTEM	Outlet: R3/4 (Rear)
COMPRESSOR	Hermetic
CONDENSER	Spiral Tube Type , Air-cooled
EVAPORATOR	Tube coiled around Cylinder (Soldier Plated)
REFRIGERANT	R290
BIN CONTROL	Actuator and Reed Switch (Time delay controlled)
ICE MAKING WATER CONTROL	Float Switch and Solenoid Valve
ELECTRICAL SAFETY PROTECTION	Circuit Breaker, Earth Wire
REFRIGERANT SAFETY PROTECTION	Compressor Internal Thermostat (Auto-reset), Pressure Switch (Auto-reset)
MECHANISM PROTECTION	Micro Switch (Manual-reset)
INTERLOCK	Shutdown by Microprocessor (Manual-reset)
WEIGHT	Net: 81kg(Gross: 88kg)
PACKAGE	Carton 665(W)x 820(D)x 950mm(H)
ACCESSORIES	Mounting Bracket, Installation Kit
OPERATING CONDITIONS	Ambient Temp.: 5 - 40°C, Water Supply Temp.: 5-35°C Water Supply Pressure: 0.05-0.8MPa(0.5-8bar) Voltage Range: Rated Voltage±6%

*We reserve the right to make changes in specifications and design without prior notice.

1. Install the ice maker properly in accordance with the instructions on location, water supply/drain connections and electrical connections stated in the instruction and installation manuals provided.
2. The ice production depends on the ambient and water temperatures. Refer to the instruction manual.
3. Product Code: F088

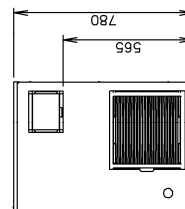
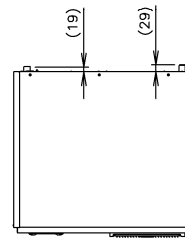
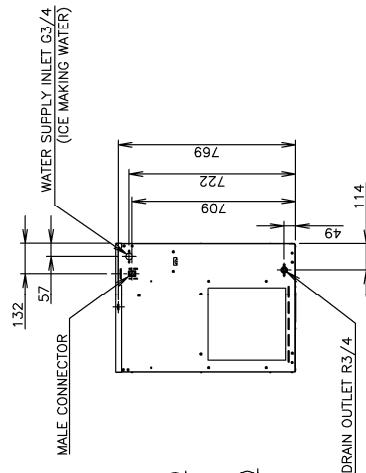
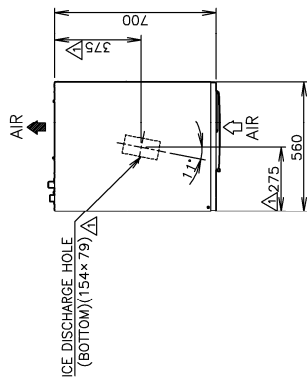

[c] FM-300AKE-HCN (Auxiliary code: D-0 or earlier)

ITEM	HOSHIZAKI NUGGET ICE MAKER
MODEL	FM-300AKE-HCN
POWER SUPPLY	1 Phase 220V-240V 50Hz Capacity: 1.53kVA (6.4A)
AMPERAGE	5.1A Starting: 20A
ELECTRIC CONSUMPTION	960W (Power Factor: 84.2%) Approx.250kg (Ambient Temp. 10C, Water Temp. 10C) Approx.210kg (Ambient Temp. 21C, Water Temp. 15C) Approx.175kg (Ambient Temp. 32C, Water Temp. 21C)
ICE PRODUCTION PER 24H	
SHAPE OF ICE	Nugget
MAX. STORAGE CAPACITY	Not Applicable
WATER CONSUMPTION PER 24H	Approx.0.250m ³ (Ambient Temp. 10C, Water Temp. 10C) Approx.0.210m ³ (Ambient Temp. 21C, Water Temp. 15C) Approx.0.175m ³ (Ambient Temp. 32C, Water Temp. 21C)
OUTSIDE DIMENSIONS	560(W) x 700(D) x 780mm(H)
HEAT REJECTION	1840W(Ambient temp.32C;Water temp.21C)
CABINET	Stainless Steel, Galvanized Steel (Rear)
ICE MAKING SYSTEM	Thin ice forming inside Cylinder (Nugget Ice)
WATER SUPPLY SYSTEM	Direct Connection to Water Main, Inlet: G3/4 (Rear)
DRAIN SYSTEM	Outlet: R3/4 (Rear)
COMPRESSOR	Hermetic
CONDENSER	Spiral Tube Type, Air-cooled
EVAPORATOR	Tube coiled around Cylinder (Solder Plated)
REFRIGERANT	R290
BIN CONTROL	Actuator and Reed Switch (Time delay controlled)
ICE MAKING WATER CONTROL	Float Switch and Solenoid Valve
ELECTRICAL SAFETY PROTECTION	Circuit Breaker, Earth Wire
REFRIGERANT SAFETY PROTECTION	Compressor Internal Thermal (Auto-reset), Pressure Switch (Auto-reset)
MECHANISM PROTECTION	Microswitch (Manual-reset)
INTERLOCK	Shutdown by Microprocessor (Manual-reset)
WEIGHT	Net: 81kg(Gross: 88kg)
PACKAGE	Carton 671(W)x 820(D)x 971mm(H)
ACCESSORIES	Mounting Bracket, Installation Kit
OPERATING CONDITIONS	Ambient Temp.: 5 - 40°C, Water Supply Temp.: 5-35°C Water Supply Pressure: 0.05 - 0.8MPa(0.5 - 8bar) Voltage Range: Rated Voltage±6%

*We reserve the right to make changes in specifications and design without prior notice.

1. Install the ice maker properly in accordance with the instructions on location, water supply/drain connections and electrical connections stated in the instruction and installation manuals provided.
2. The ice production depends on the ambient and water temperatures. Refer to the instruction manual.
3. Product Code: F088-C106

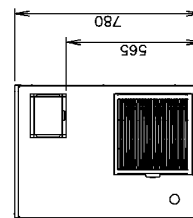
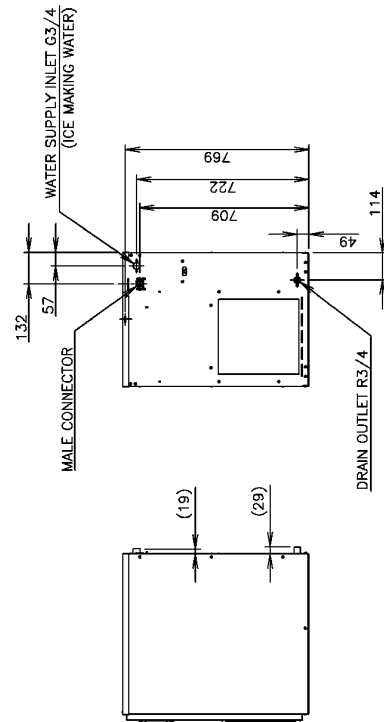
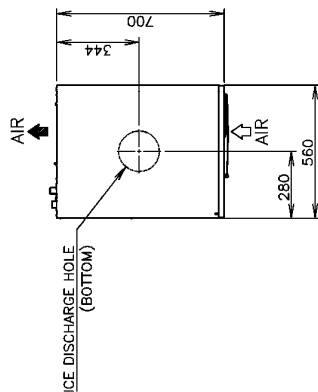

[d] FM-300AKE-HCN (Auxiliary code: D-1 or later)

ITEM	HOSHIZAKI NUGGET ICE MAKER
MODEL	FM-300AKE-HCN
POWER SUPPLY	1 Phase 220V-240V 50Hz Capacity: 1.53kVA (6.4A)
AMPERAGE	5.1A Starting: 20A
ELECTRIC CONSUMPTION	960W (Power Factor: 84.2%)
ICE PRODUCTION PER 24h	Approx.250kg (Ambient Temp. 10°C, Water Temp. 10°C) Approx.210kg (Ambient Temp. 21°C, Water Temp. 15°C) Approx.175kg (Ambient Temp. 32°C, Water Temp. 21°C)
SHAPE OF ICE	Nugget
MAX. STORAGE CAPACITY	Not Applicable
WATER CONSUMPTION PER 24h	Approx.0.250m ³ (Ambient Temp. 10°C, Water Temp. 10°C) Approx.0.210m ³ (Ambient Temp. 21°C, Water Temp. 15°C) Approx.0.175m ³ (Ambient Temp. 32°C, Water Temp. 21°C)
OUTSIDE DIMENSIONS	560(W) x 700(D) x 780mm(H)
HEAT REJECTION	1840W(Ambient temp.32°C,Water temp.21°C)
CABINET	Stainless Steel, Galvanized Steel (Rear)
ICE MAKING SYSTEM	Thin ice farming inside Cylinder (Nugget Ice)
WATER SUPPLY SYSTEM	Direct Connection to Water Main, Inlet: G3/4 (Rear)
DRAIN SYSTEM	Outlet: R3/4 (Rear)
COMPRESSOR	Hermetic
CONDENSER	Spiral Tube Type, Air-cooled
EVAPORATOR	Tube coiled around Cylinder (Solder Plated)
REFRIGERANT	R290
BIN CONTROL	Actuator and Reed Switch (Time delay controlled)
BELOWING WATER CONTROL	Float Switch and Solenoid Valve
ELECTRICAL CIRCUIT PROTECTION	Circuit Breaker, Earth Wire
REFRIGERANT CIRCUIT PROTECTION	Compressor Internal Thermostat (Auto-reset), Pressure Switch (Auto-reset)
MECHANISM PROTECTION	Microswitch (Manual-reset)
INTERLOCK	Shutdown by Microprocessor (Manual-reset)
WEIGHT	Net: 81kg(Gross: 88kg)
PACKAGE	Carton 665(W)x 820(D)x 950mm(H)
ACCESSORIES	Mounting Bracket, Installation Kit
OPERATING CONDITIONS	Ambient Temp.: 5 - 40°C, Water Supply Temp.: 5-35°C Water Supply Pressure: 0.05-0.8MPa(0.5-8bar) Voltage Range: Rated Voltage±6%

*We reserve the right to make changes in specifications and design without prior notice.

1. Install the ice maker properly in accordance with the instructions on location, water supply/drain connections and electrical connections stated in the instruction and installation manuals provided.
2. The ice production depends on the ambient and water temperatures. Refer to the instruction manual.
3. Product Code: F088-C106

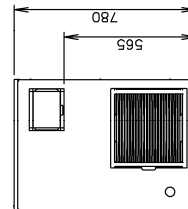
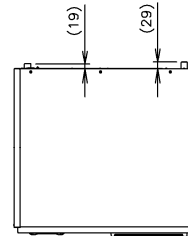
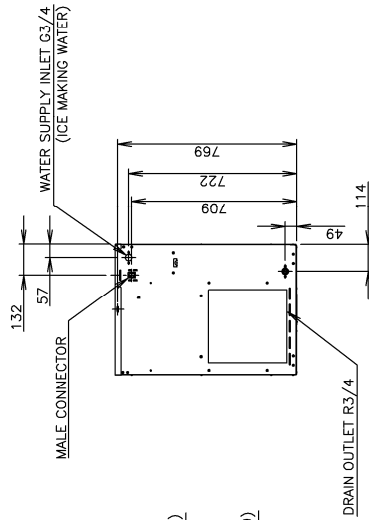
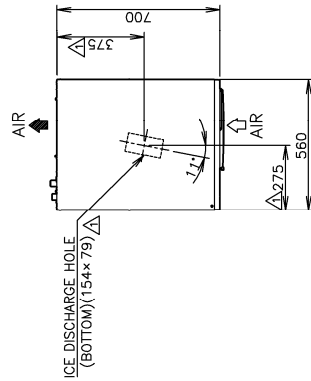

[e] FM-480AKE-HC (Auxiliary code: D-0 or earlier)

ITEM	HOSHIZAKI FLAKE ICE MAKER
MODEL	FM-480AKE-HC
POWER SUPPLY	1 Phase 220V-240V 50Hz Capacity: 2.2kVA (8.8A)
AMPERAGE	5.3A Starting: 27A
ELECTRIC CONSUMPTION	1100W (Power Factor: 89.1%)
ICE PRODUCTION PER 24H	Approx.450kg (Ambient Temp. 10°C, Water Temp. 10°C) Approx.400kg (Ambient Temp. 21°C, Water Temp. 15°C) Approx.340kg (Ambient Temp. 32°C, Water Temp. 21°C)
SHAPE OF ICE	Flake
MAX. STORAGE CAPACITY	Not Applicable
WATER CONSUMPTION PER 24H	Approx.3,450m ³ (Ambient Temp. 10°C, Water Temp. 10°C) Approx.3,400m ³ (Ambient Temp. 21°C, Water Temp. 15°C) Approx.3,340m ³ (Ambient Temp. 32°C, Water Temp. 21°C)
OUTSIDE DIMENSIONS	560(W) x 700(D) x 780mm(H)
HEAT REJECTION	2190W(Ambient temp.32°C,Water temp.21°C)
CABINET	Stainless Steel, Galvanized Steel (Rear)
ICE MAKING SYSTEM	Thin ice forming inside Cylinder (Flake Ice)
WATER SUPPLY SYSTEM	Direct Connection to Water Main, Inlet: G3/4 (Rear)
DRAIN SYSTEM	Outlet: R3/4 (Rear)
COMPRESSOR	Hermetic
CONDENSER	Spiral Tube Type, Air-cooled
EVAPORATOR	Tube coiled around Cylinder (Solder Plated)
REFRIGERANT	R290
BIN CONTROL	Actuator and Reed Switch (Time delay controlled)
ICE MAKING WATER CONTROL	Float Switch and Solenoid Valve
ELECTRICAL CIRCUIT PROTECTION	Circuit Breaker, Earth Wire
ROTARY OVERLOAD PROTECTION	Compressor Internal Thermostat (Auto-reset), Pressure Switch (Auto-reset)
MECHANISM PROTECTION	Micro Switch (Manual-reset)
INTERLOCK	Shutdown by Microprocessor (Manual-reset)
WEIGHT	Net: 92kg(Gross: 99kg)
PACKAGE	Carton 671(W)x820(D)x971mm(H)
ACCESSORIES	Mounting Bracket, Installation Kit
OPERATING CONDITIONS	Ambient Temp.: 5 - 40°C, Water Supply Temp.: 5-35°C Water Supply Pressure: 0.05-0.8MPa(0.5-8bar) Voltage Range: Rated Voltage±6%

*We reserve the right to make changes in specifications and design without prior notice.

1. Install the ice maker properly in accordance with the instructions on location, water supply/drain connections and electrical connections stated in the instruction and installation manuals provided.
2. The ice production depends on the ambient and water temperatures. Refer to the instruction manual.
3. Product Code: F087

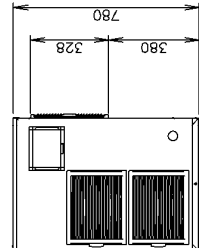
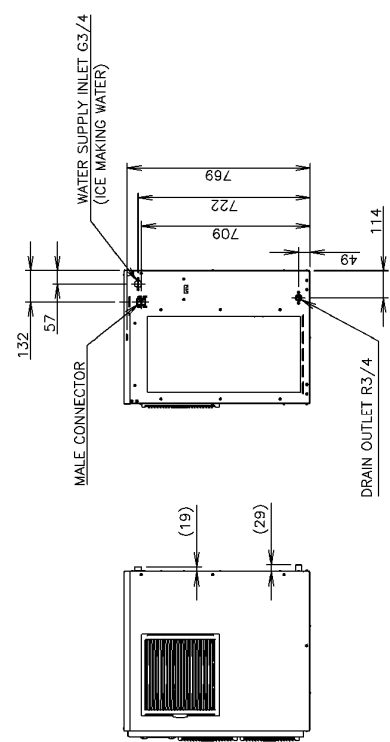
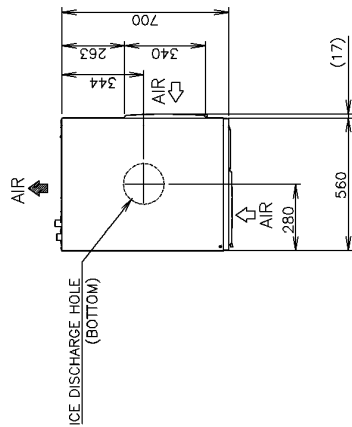

[f] FM-480AKE-HC (Auxiliary code: D-1 or later)

ITEM	HOSHIZAKI FLAKE ICE MAKER
MODEL	FM-480AKE-HC
POWER SUPPLY	1 Phase 220V-240V 50Hz Capacity: 2.2kVA (8.8A)
AMPERAGE	5.3A Starting: 27A
ELECTRIC CONSUMPTION	1100W (Power Factor: 89.1%) Approx.450kg (Ambient Temp. 10°C, Water Temp. 10°C) Approx.400kg (Ambient Temp. 21°C, Water Temp. 15°C) Approx.340kg (Ambient Temp. 32°C, Water Temp. 21°C)
ICE PRODUCTION PER 24H	
SHAPE OF ICE	Flake
MAX. STORAGE CAPACITY	Not Applicable
WATER CONSUMPTION PER 24H	Approx.0.450m ³ (Ambient Temp. 10°C, Water Temp. 10°C) Approx.0.400m ³ (Ambient Temp. 21°C, Water Temp. 15°C) Approx.0.340m ³ (Ambient Temp. 32°C, Water Temp. 21°C)
OUTSIDE DIMENSIONS	560(W) x 700(D) x 780mm(H)
HEAT REJECTION	2190W (Ambient temp.32°C, Water temp.21°C)
CABINET	Stainless Steel, Galvanized Steel (Rear)
ICE MAKING SYSTEM	Thin ice forming inside Cylinder (Flake Ice)
WATER SUPPLY SYSTEM	Direct Connection to Water Main, Inlet: G3/4 (Rear)
DRAIN SYSTEM	Outlet: R3/4 (Rear)
COMPRESSOR	Hermetic
CONDENSER	Spiral Tube Type , Air-cooled
EVAPORATOR	Tube coiled around Cylinder (Solder Plated)
REFRIGERANT	R290
BIN CONTROL	Actuator and Reed Switch (Time delay controlled)
ICE MAKING WATER CONTROL	Float Switch and Solenoid Valve
ELECTRICAL PROTECTION	Circuit Breaker, Earth Wire
REFRIGERANT PROTECTION	Compressor Internal Thermostat (Auto-reset), Pressure Switch (Auto-reset)
MECHANICAL PROTECTION	Micro Switch (Manual-reset)
INTERLOCK	Shutdown by Microprocessor (Manual-reset)
WEIGHT	Net: 92kg(Gross: 99kg)
PACKAGE	Carton 665(W)x 820(D)x 950mm(H)
ACCESSORIES	Mounting Bracket, Installation Kit
OPERATING CONDITIONS	Ambient Temp.: 5 - 40°C, Water Supply Temp.: 5-35°C Water Supply Pressure: 0.05-0.8MPa(0.5-8bar) Voltage Range: Rated Voltage±6%

*We reserve the right to make changes in specifications and design without prior notice.

1. Install the ice maker properly in accordance with the instructions on location, water supply/drain connections and electrical connections stated in the instruction and installation manuals provided.
2. The ice production depends on the ambient and water temperatures. Refer to the instruction manual.
3. Product Code: F087

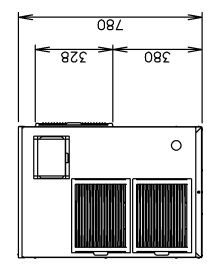
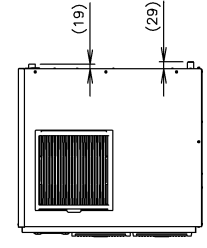
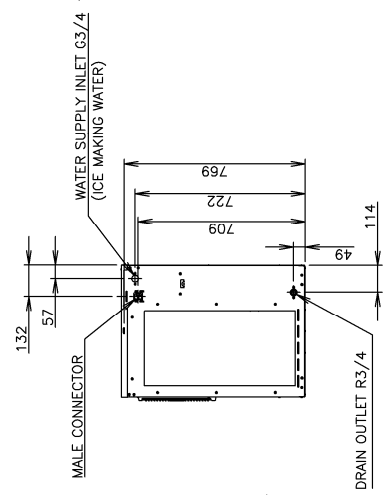
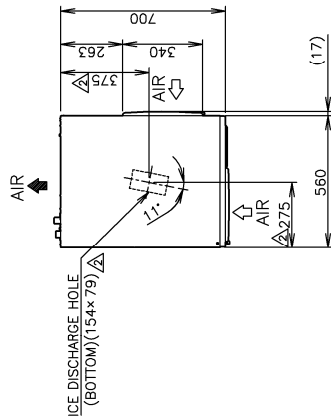

[g] FM-480AKE-HCN (Auxiliary code: D-0 or earlier)

ITEM	HOSHIZAKI NUGGET ICE MAKER
MODEL	FM-480AKE-HCN
POWER SUPPLY	1 Phase 220V-240V 50Hz Capacity: 2.2kVA (8.8A)
AMPERAGE	5.6A Starting: 27A
ELECTRIC CONSUMPTION	1170W (Power Factor: 90.7%)
ICE PRODUCTION PER 24h	Approx.380kg (Ambient Temp. 10c, Water Temp. 10°C) Approx.330kg (Ambient Temp. 21c, Water Temp. 15°C) Approx.270kg (Ambient Temp. 32c, Water Temp. 21°C)
SHAPE OF ICE	Nugget
MAX. STORAGE CAPACITY	Not Applicable
WATER CONSUMPTION PER 24h	Approx.0.380m ³ (Ambient Temp. 10c, Water Temp. 10°C) Approx.0.330m ³ (Ambient Temp. 21c, Water Temp. 15°C) Approx.0.270m ³ (Ambient Temp. 32c, Water Temp. 21°C)
OUTSIDE DIMENSIONS	560(W) x 700(D) x 780mm(H)
HEAT REJECTION	2190W(Ambient temp.32c,Water temp.21°C)
CABINET	Stainless Steel, Galvanized Steel (Rear)
ICE MAKING SYSTEM	Thin ice forming inside Cylinder (Nugget Ice)
WATER SUPPLY SYSTEM	Direct Connection to Water Main, Inlet: G3/4 (Rear)
DRAIN SYSTEM	Outlet: R3/4 (Rear)
COMPRESSOR	Hermetic
CONDENSER	Spiral Tube Type, Air-cooled
EVAPORATOR	Tube coiled around Cylinder (Solder Plated)
REFRIGERANT	R290
BIN CONTROL	Actuator and Reed Switch (Time delay controlled)
FEEDING WATER CONTROL	Float Switch and Solenoid Valve
ELECTRICAL CIRCUIT PROTECTION	Circuit Breaker, Earth Wire
REFRIGERANT CIRCUIT PROTECTION	Compressor Internal Thermostat (Auto-reset), Pressure Switch (Auto-reset)
MECHANISM PROTECTION	Microswitch (Manual-reset)
INTERLOCK	Shutdown by Microprocessor (Manual-reset)
WEIGHT	Net: 92kg(Gross: 99kg)
PACKAGE	Carton 671(W)×820(D)×971mm(H)
ACCESSORIES	Mounting Bracket, Installation Kit
OPERATING CONDITIONS	Ambient Temp.: 5 - 40°C, Water Supply Temp.: 5-35°C Water Supply Pressure: 0.05-0.8MPa(0.5-8bar) Voltage Range: Rated Voltage±6%

*We reserve the right to make changes in specifications and design without prior notice.

1. Install the ice maker properly in accordance with the instructions on location, water supply/drain connections and electrical connections stated in the instruction and installation manuals provided.
2. The ice production depends on the ambient and water temperatures. Refer to the instruction manual.
3. Product Code: F087-C106

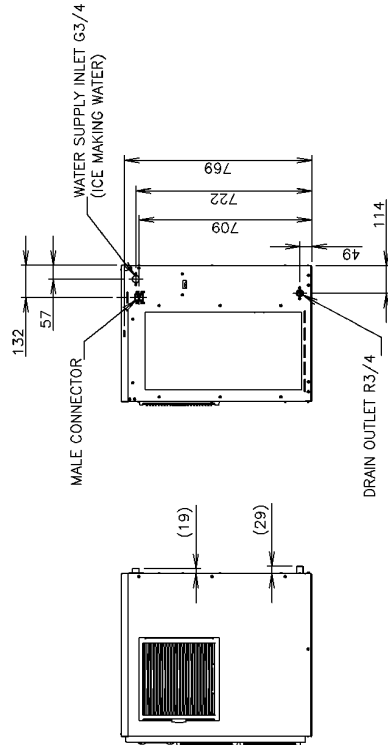
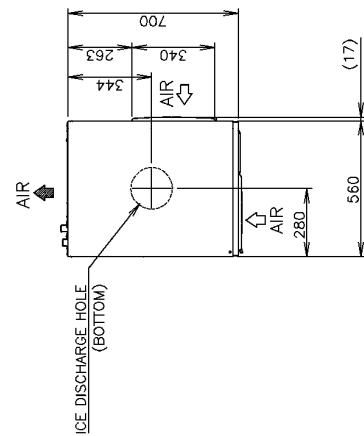

[h] FM-480AKE-HCN (Auxiliary code: D-1 or later)

ITEM	HOSHIZAKI NUGGET ICE MAKER
MODEL	FM-480AKE-HCN
POWER SUPPLY	1 Phase 220V-240V 50Hz Capacity: 2.2kVA (8.8A)
AMPERAGE	5.6A Starting: 27A
ELECTRIC CONSUMPTION	1170W (Power Factor: 90.7%)
ICE PRODUCTION PER 24h	Approx.380kg (Ambient Temp. 10°C, Water Temp. 10°C) Approx.330kg (Ambient Temp. 21°C, Water Temp. 15°C) Approx.270kg (Ambient Temp. 32°C, Water Temp. 21°C)
SHAPE OF ICE	Nugget
MAX. STORAGE CAPACITY	Not Applicable
WATER CONSUMPTION PER 24h	Approx.0.380m ³ (Ambient Temp. 10°C, Water Temp. 10°C) Approx.0.330m ³ (Ambient Temp. 21°C, Water Temp. 15°C) Approx.0.270m ³ (Ambient Temp. 32°C, Water Temp. 21°C)
OUTSIDE DIMENSIONS	560(W) x 700(D) x 780mm(H)
HEAT REJECTION	2190W(Ambient temp.32°C, Water temp.21°C)
CABINET	Stainless Steel, Galvanized Steel (Rear)
ICE MAKING SYSTEM	Thin ice forming inside Cylinder (Nugget Ice)
WATER SUPPLY SYSTEM	Direct Connection to Water Main, Inlet: G3/4 (Rear)
DRAIN SYSTEM	Outlet: R3/4 (Rear)
COMPRESSOR	Hermetic
CONDENSER	Spiral Tube Type, Air-cooled
EVAPORATOR	Tube coiled around Cylinder (Solder Plated)
REFRIGERANT	R290
BIN CONTROL	Actuator and Reed Switch (Time delay controlled)
ICE MAKING WATER CONTROL	Float Switch and Solenoid Valve
ELECTRICAL CIRCUT PROTECTION	Circuit Breaker, Earth Wire
REFRIGERANT CIRCUT PROTECTION	Compressor Internal Thermostat (Auto-reset), Pressure Switch (Auto-reset)
MECHANISM PROTECTION	Microswitch (Manual-reset)
INTERLOCK	Shutdown by Microprocessor (Manual-reset)
WEIGHT	Net: 92kg(Gross: 99kg)
PACKAGE	Carton 665(W)x 820(D)x 950mm(H)
ACCESSORIES	Mounting Bracket, Installation Kit
OPERATING CONDITIONS	Ambient Temp: 5 - 40°C, Water Supply Temp: 5-35°C Water Supply Pressure: 0.05-0.8MPa(0.5-8bar) Voltage Range: Rated Voltage±6%

We reserve the right to make changes in specifications and design without prior notice.

1. Install the ice maker properly in accordance with the instructions on location, water supply/drain connections and electrical connections stated in the instruction and installation manuals provided.
2. The ice production depends on the ambient and water temperatures. Refer to the instruction manual.
3. Product Code: F087-C106

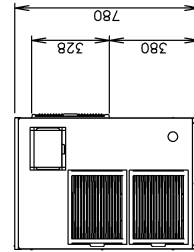
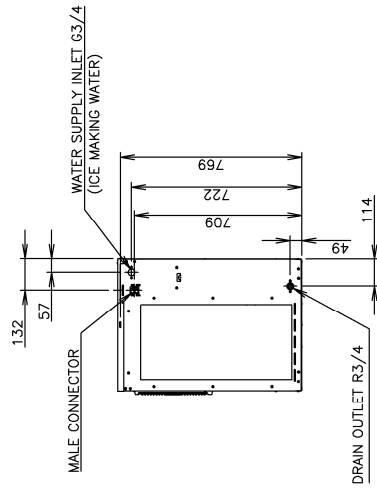
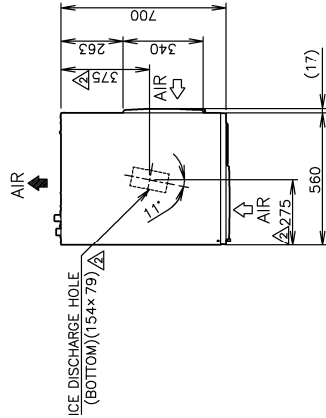

2. CONSTRUCTION

[a] FM-300AKE-HC(N) (Auxiliary code: D-0 or earlier)

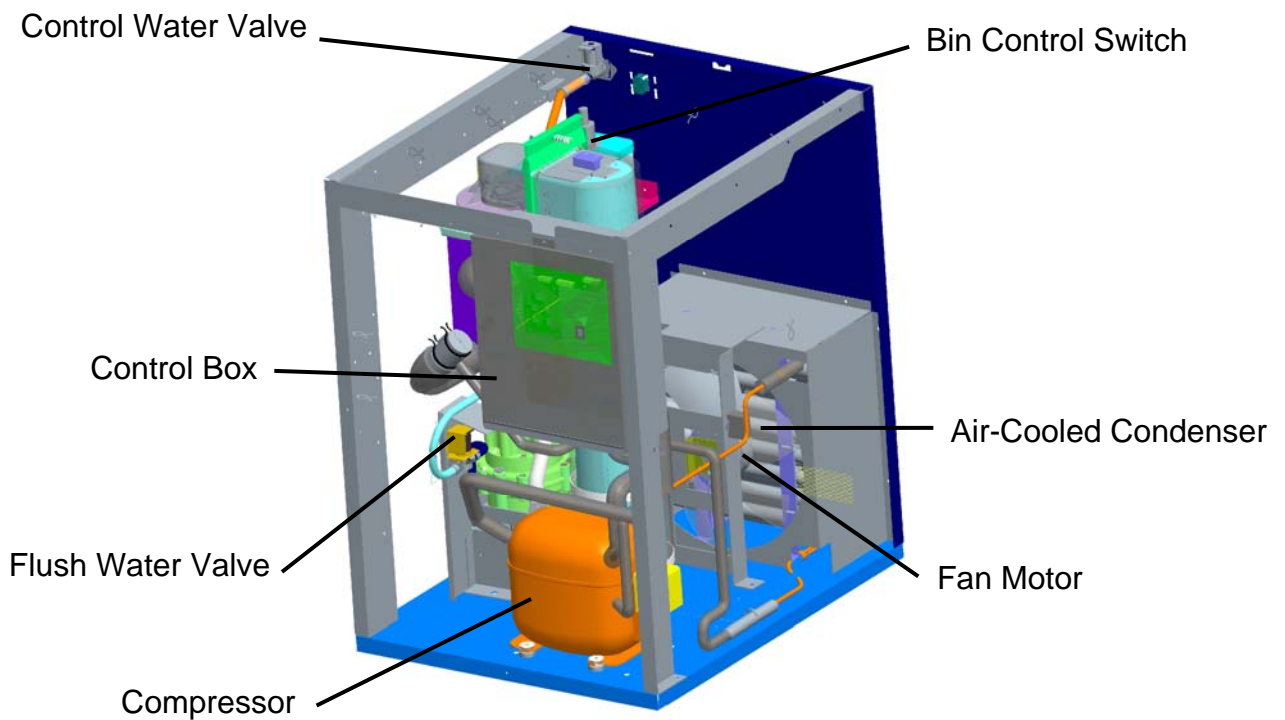
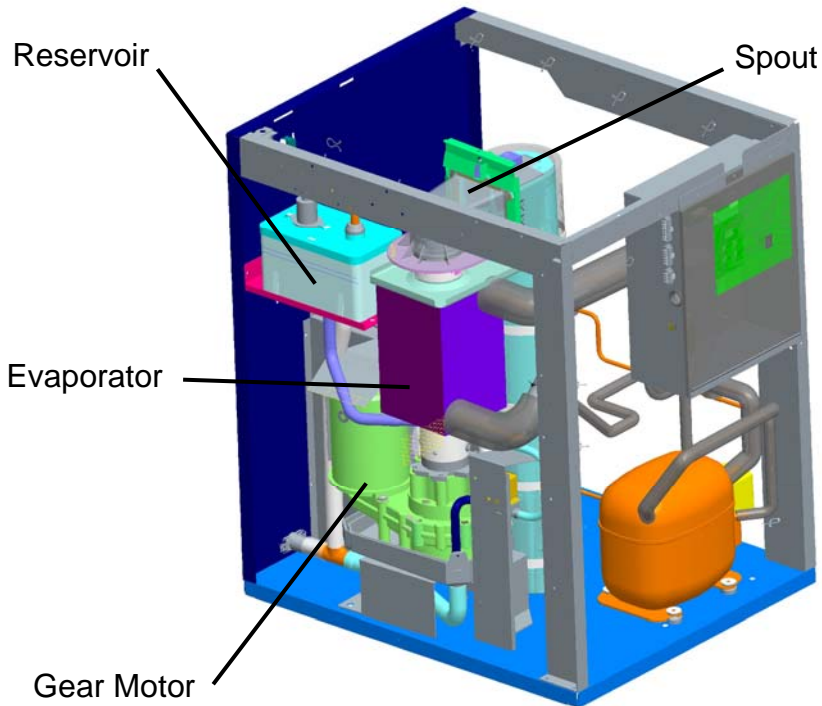

[b] FM-480AKE-HC(N) (Auxiliary code: D-0 or earlier)

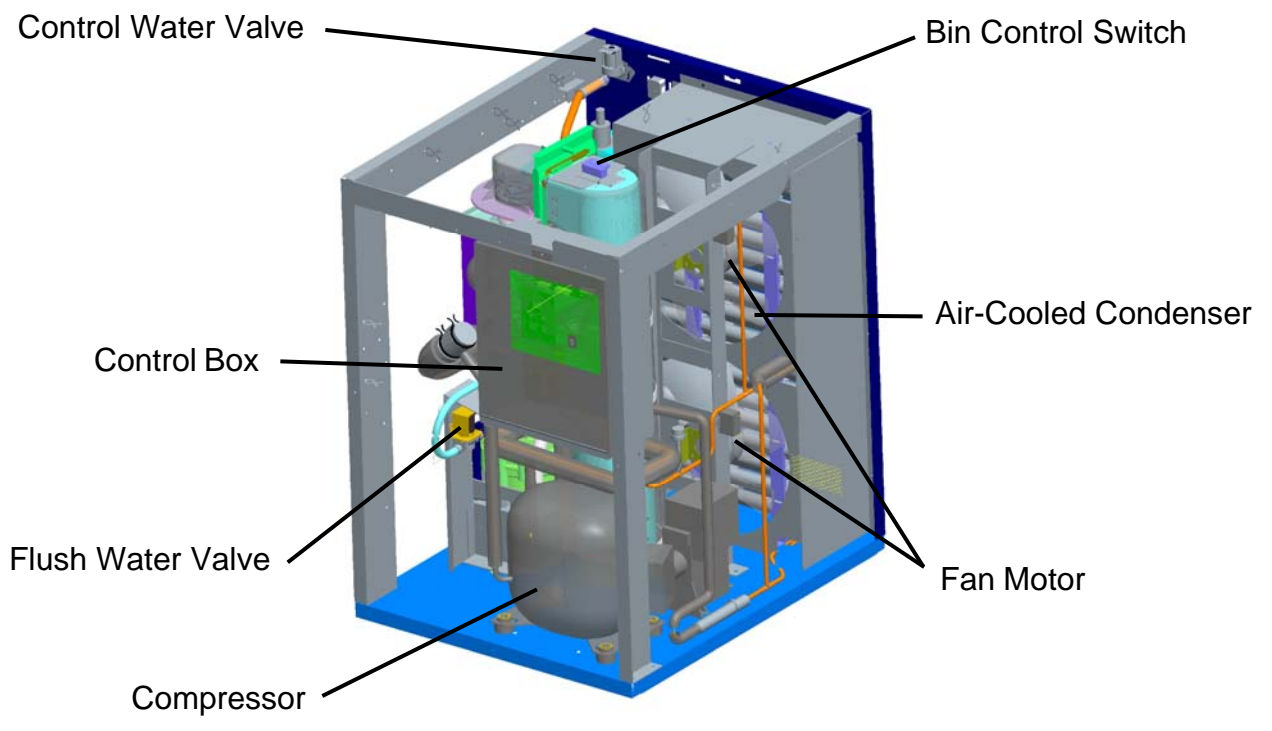
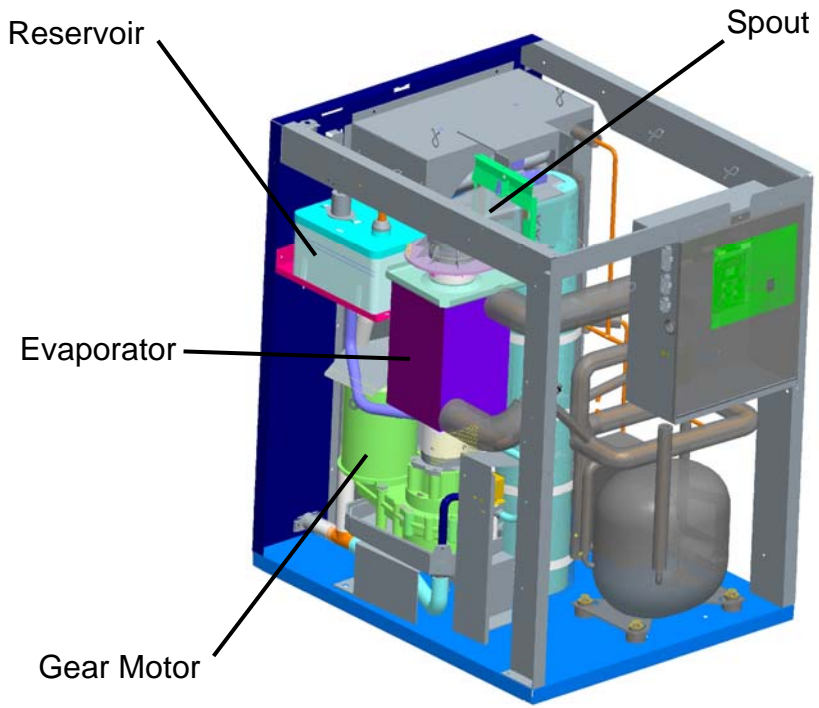

[c] FM-300AKE-HC(N), FM-480AKE-HC(N) (Auxiliary code: D-1 or later)

See [a] or [b] for the entire construction.

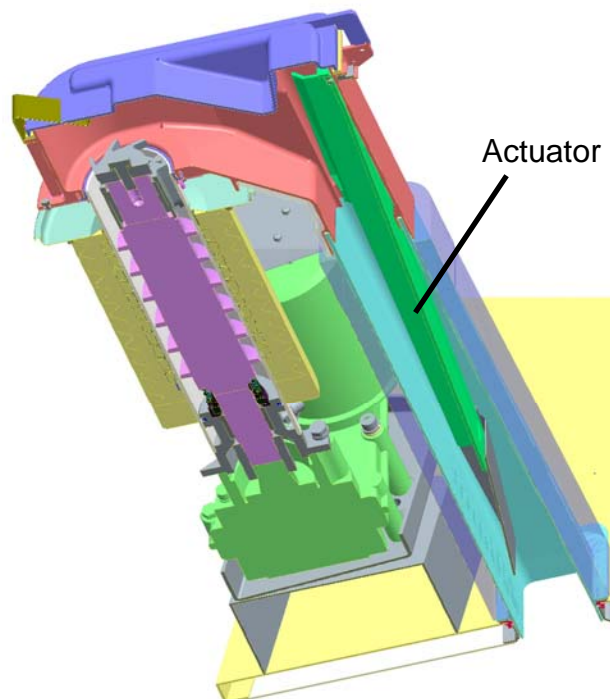
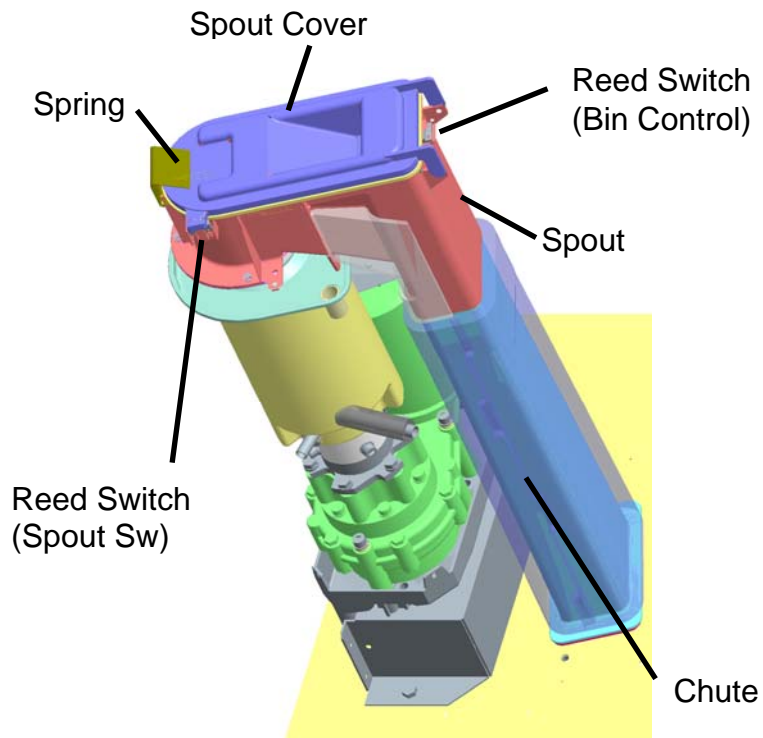

II. MAINTENANCE AND CLEANING INSTRUCTIONS

IMPORTANT

1. This icemaker must be maintained individually, referring to the instruction manual and labels provided with the icemaker.
2. To achieve optimum icemaker performance, the following parts need periodic inspection and maintenance:
 - Extruding head (upper bearing)
 - Housing (lower bearing)
 - Mechanical seal

These parts should be inspected after two years from installation or 10,000 hours of operation, whichever comes first, and once a year thereafter. Their service life, however, depends on water quality and environment. More frequent inspection and maintenance are recommended in bad or severe water conditions.

1. EXTRUDING HEAD (UPPER BEARING), HOUSING (LOWER BEARING)

These parts should be replaced if a diametrical gap of more than 0.5 mm is found when at least three spots are checked by changing the direction of the auger on each bearing.

It depends on the water quality and conditions, but normally the bearings should be checked for wear after a total of 8,000 - 10,000 hour operation from installation date.

Note: The clearance between the auger blades and the evaporator interior is 0.4 - 0.5 mm. If the bearings and rotating parts are worn out to create a larger clearance, the evaporator interior may be damaged. (The diameters differ by 0.8 - 1.0 mm.)

If the auger surfaces against which the bearings contact are no longer smooth or show any burrs or abrasions during the above inspection, replace the auger. The sealing bolt must be tightened equally to torque of $784\text{N}\cdot\text{cm} \pm 10\%$.

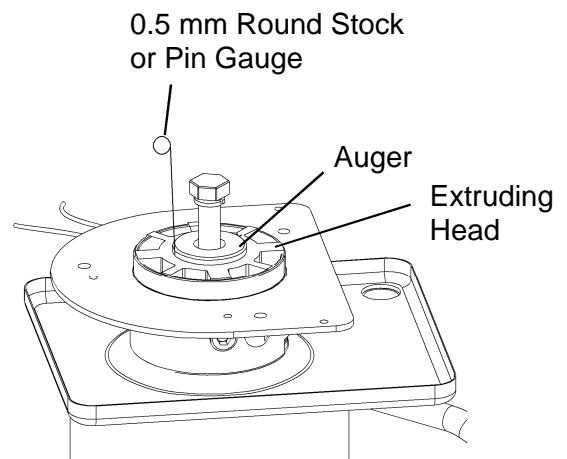

For reference only
(May differ from actual design)

2. MECHANICAL SEAL

The mechanical seal prevents water leaks from between the auger and the housing bearing and gradually wears out to reduce its watertightness. Check the amount of water leakage from the drain pipe located at the side of the gear case to determine the necessity of replacement.

<u>Total operation time</u>	<u>Water leakage</u>
3,000 hours	0.1 mL/h
10,000 hours	0.5 mL/h

Attach the mechanical seal with its floating sheet facing the housing. After replacement, there should be no water leakage from the mating surface.

Note: The water leakage will exceed the above amount with scale/dirt build up or damage on the mating surface. Replace the mechanical seal when the water leakage exceeds 0.5 mL/h.

3. GEAR MOTOR

After the following hours of operation, check the gear motor for excessive noise caused by increased torque or deterioration of mechanical parts.

Bearing, gear and other mechanical parts:	10,000 hours
Oil seal:	5 years

Note: When the output shaft oil seal is exposed to a large amount of water at one time, water may enter the gear case. Always drain the water circuit before removing the auger for service.

4. CONDENSER

Check the condenser once a year, and clean if required by using a brush or vacuum cleaner. More frequent cleaning may be required depending on the location of the icemaker.

5. AIR FILTER

Plastic mesh air filters remove dirt or dust from the air, and keep the condenser from getting clogged. If the filters get clogged, the icemaker's performance will be reduced. Remove and clean the air filters at least twice per month:

- 1) Slide the air filter off the louver.
- 2) Clean the air filter by using a vacuum cleaner. When severely clogged, use warm water and a neutral cleaner to wash the air filter.
- 3) Rinse and dry the air filter thoroughly, and place it in position.

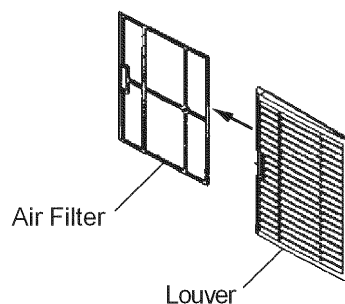

6. CONTROL WATER VALVE

- 1) Disconnect the power source.
- 2) Close the water supply tap.
- 3) Disconnect the inlet hose from the water valve.
- 4) Clean the filter packing using a brush.
- 5) Replace the filter packing and inlet hose in their correct positions.
- 6) Open the water supply tap.
- 7) Connect the power source.
- 8) Check for leaks.

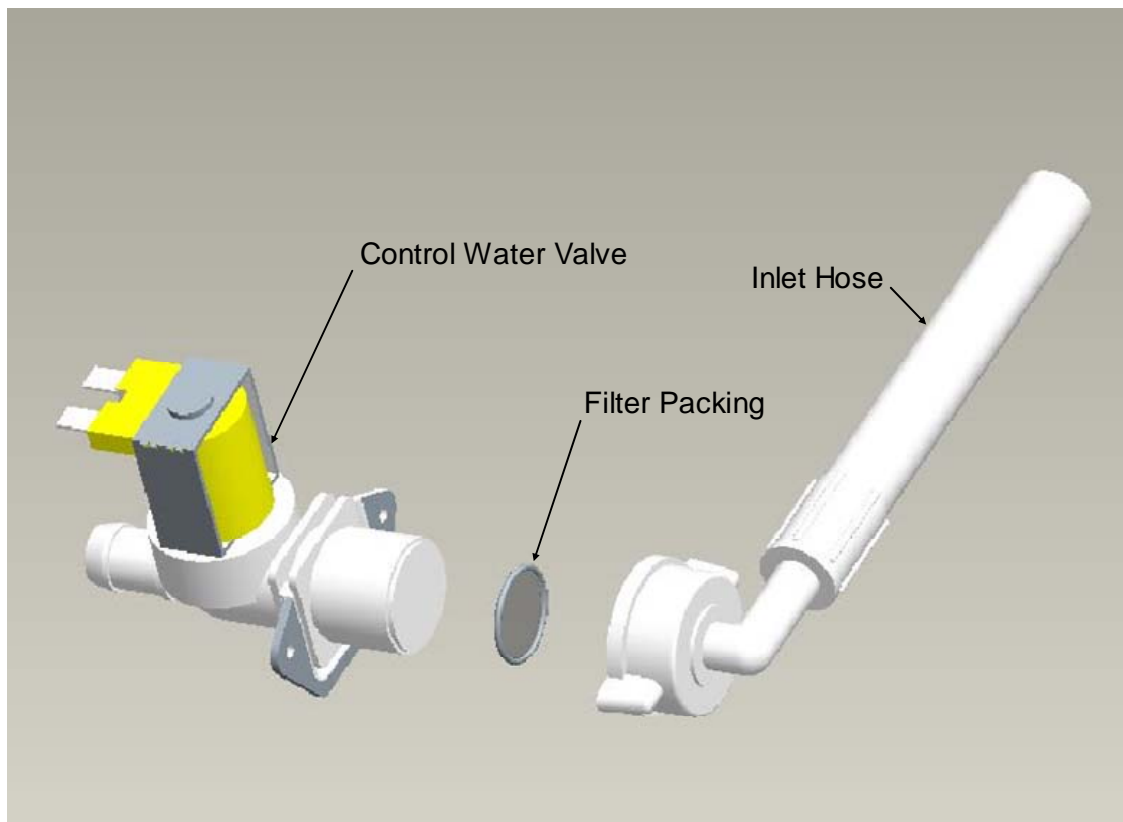

7. CLEANING OF WATER SYSTEM

WARNING

1. HOSHIZAKI recommends cleaning this unit at least twice a year. More frequent cleaning, however, may be required in some existing water conditions.
2. Do not touch the operation switch with damp hands.
3. Always wear rubber gloves, eye protectors, apron, etc. for safe handling of the cleaner and sanitiser.
4. Use the cleaners and sanitisers recommended by Hoshizaki. Contact your local Hoshizaki office for further details. (The instructions below give an example of those recommended cleaners and sanitisers.)
5. Never mix cleaning and sanitising solutions in an attempt to shorten cleaning time.
6. Wipe off any splashed or spilt cleaner/sanitiser immediately.
7. Do not use any ammonia type cleaners on any part of the icemaker.

CAUTION

Do not use ice produced with cleaning and sanitizing solutions. Be sure none remains in the storage bin on completion of cleaning.

<STEP 1>

Dilute the solutions with water as follows:

Cleaning solution: "Nickel-Safe Ice Machine Cleaner" by The Rectorseal Corporation or similar. Prepare approximately 3 L of solution as directed on the container.

Sanitising solution: 30 mL of 5.25% sodium hypochlorite with 7.6 L of water or the Hoshizaki recommended sanitiser as directed on the container.

IMPORTANT

For safety and maximum effectiveness, use the solutions immediately after dilution.

<STEP 2>

Use the cleaning solution to remove lime deposits in the water system.

- 1) Open the plastic access flap on the front panel.
- 2) Press the stop button to activate the flush cycle (approx. 10 minutes).

- 3) Remove all ice from the storage bin to avoid contamination by the cleaner.
- 4) Unplug the icemaker. Remove the top and front panels.
- 5) Remove the cover of the reservoir. Remove any loose debris or scale.
- 6) Carefully fill the reservoir with the solution to the overflow point. If necessary, use a small brush to clean the inside of the reservoir.
- 7) Refit the reservoir cover.
- 8) Check that the operation switch is in the "ON" position.
- 9) Refit the front and top panels.
- 10) Allow the icemaker to stand for about 10 minutes, then plug in the icemaker to make ice with the solution.
- 11) With the water supply tap open, allow the machine to continue icemaking for a further 20 minutes. Open the access flap and press the stop button.
- 12) Allow time for the gear motor to stop and the water system to drain.
- 13) Allow the icemaker to make ice for approximately 10 minutes.
- 14) Pour warm water into the storage bin to melt any ice down the drain.

Note: 1. If the machine has heavy deposits of scale, repeat the complete cleaning procedure.

2. Do not increase the proportion of cleaning solution to shorten cleaning times, as this may lock the auger when completing item 10).

<STEP 3>

Note: Sanitising should always be completed after cleaning or alternately as an individual procedure if conditions exist to make it necessary.

Use 2.8 litres of the sanitising solution to sanitise the icemaker.

- 15) Follow items 1) to 14) to complete sanitisation of the water system.

III. TECHNICAL INFORMATION

1. WATER CIRCUIT AND REFRIGERANT CIRCUIT

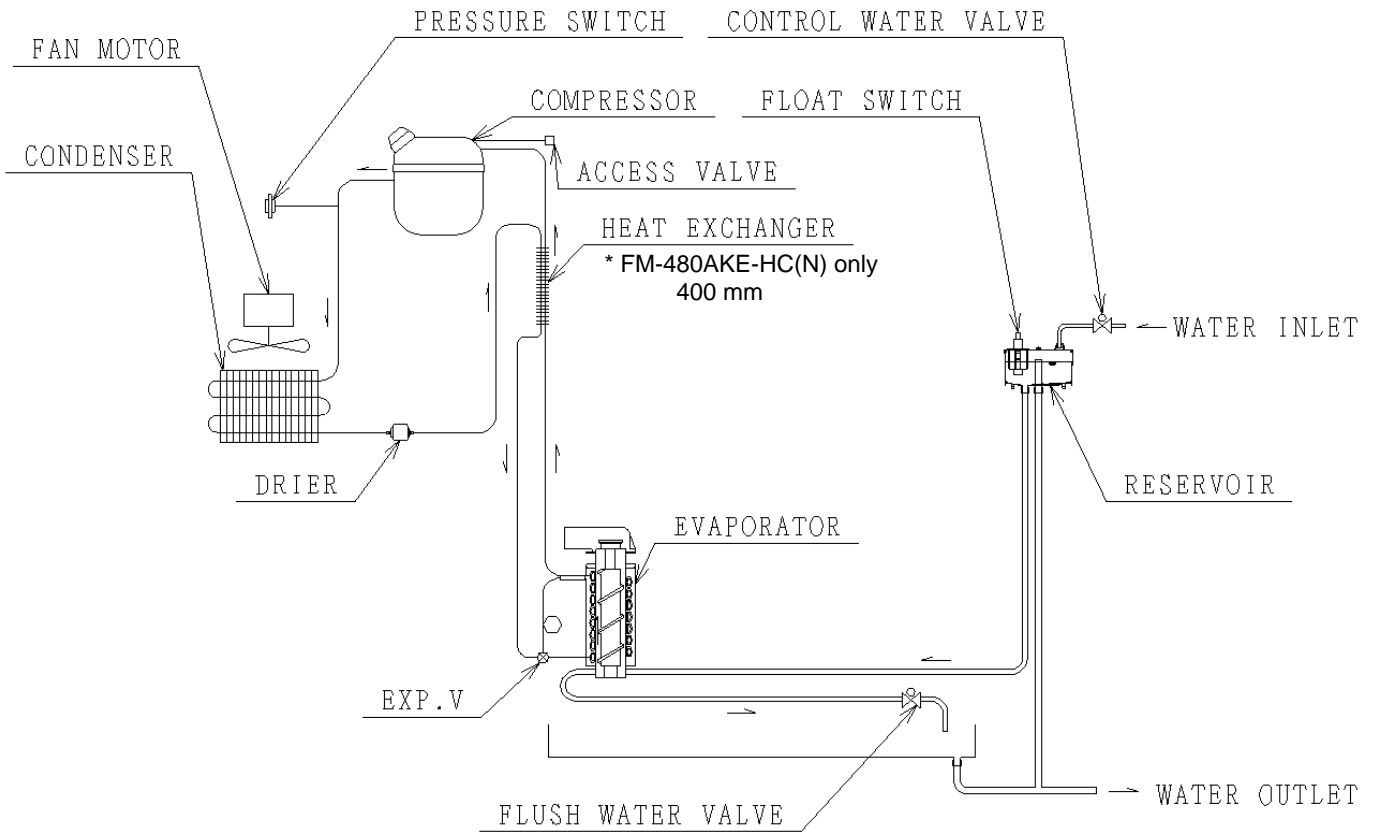

Pressure Switch
Cut-out $2.26 + 0.15/0$ MPa
Cut-in 1.57 ± 0.15 MPa

2. WIRING DIAGRAM

[a] WIRING DIAGRAM

FM-300AKE-HC(N) (Auxiliary code: D-0 or earlier)

SET No.
17

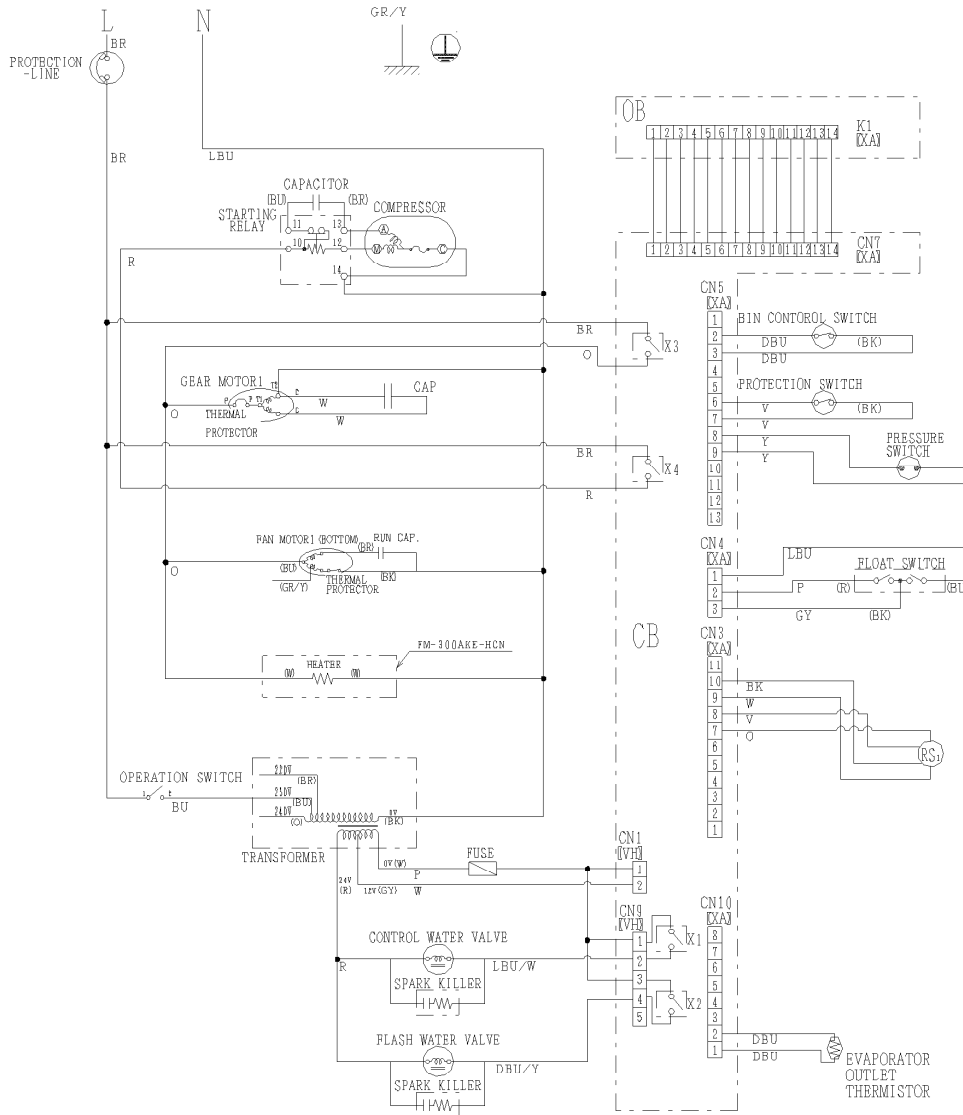

ERROR TABLE

E0, C0	ICEMAKING WATER LEAK
E1	LOW ICE PRODUCTION
E2	FLOAT SWITCH ERROR
E3, EE	GEAR MOTOR ERROR
E4	ABNORMAL HIGH SIDE
c7	PRESSURE
E5	GEAR MOTOR DRIVE ELEMENT ERROR
EF	FREQUENT VOLTAGE ERROR
EL	BIN CONTROL SWITCH ERROR
EP	MODEL NUMBER ERROR
EU	CONTROLLER BOARD ERROR
c1	LOW WATER
c3	ABNORMAL LOW VOLTAGE
c4	DRAIN ERROR

WIRE COLOR CODE

O	ORANGE
R	RED
BU	BLUE
DBU	DARK BLUE
BR	BROWN
GY	GRAY
LBU	LIGHT BLUE
P	PINK
Y	YELLOW
V	VIOLET
BK	BLACK
W	WHITE

FM-300AKE-HC(N) (Auxiliary code: D-1 or later)

SET No.
17

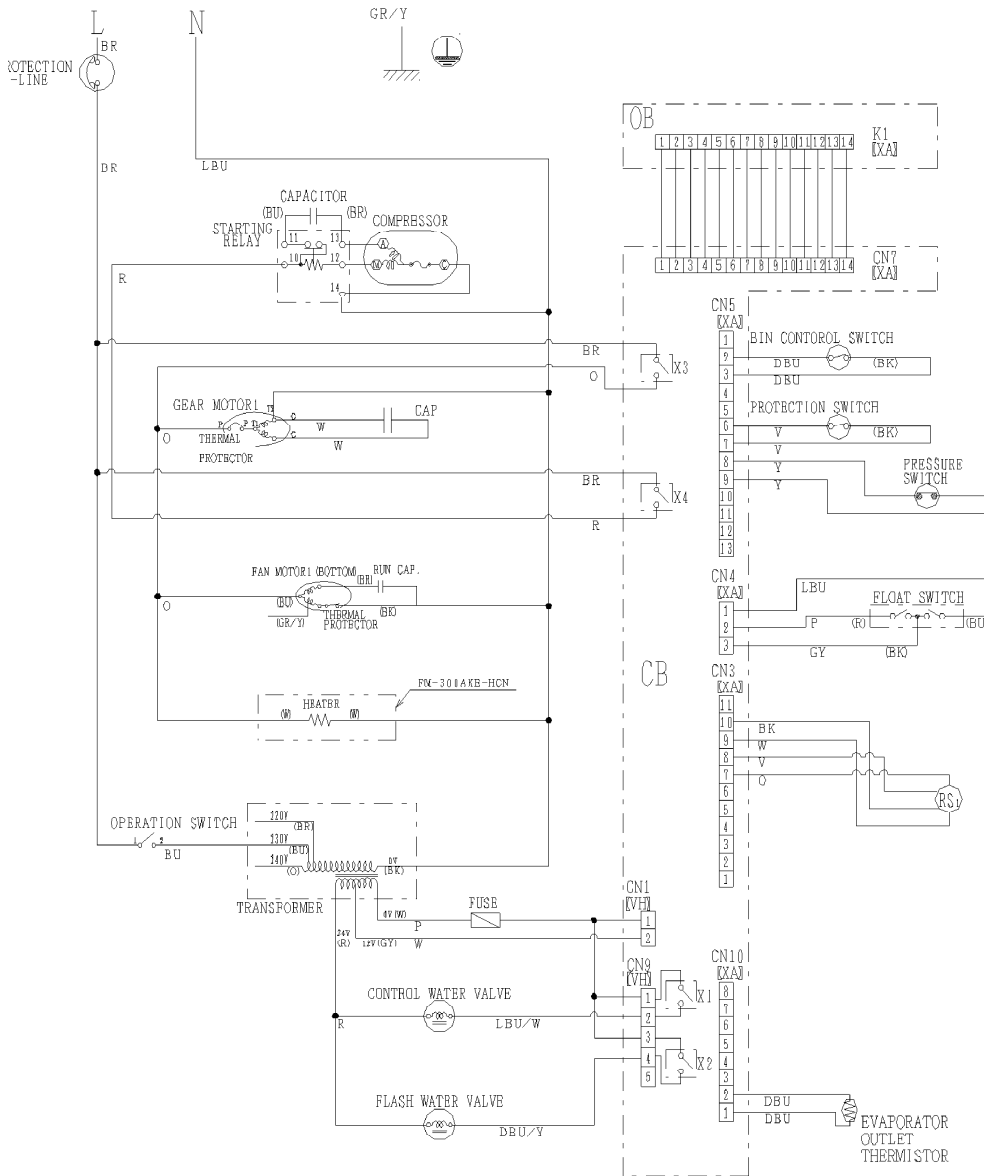

WIRE COLOR CODE

O	ORANGE
R	RED
BU	BLUE
DBU	DARK BLUE
BR	BROWN
GY	GRAY
LBU	LIGHT BLUE
P	PINK
Y	YELLOW
V	VIOLET
BK	BLACK
W	WHITE

FM-480AKE-HC(N) (Auxiliary code: D-0 or earlier)

SET No.
18

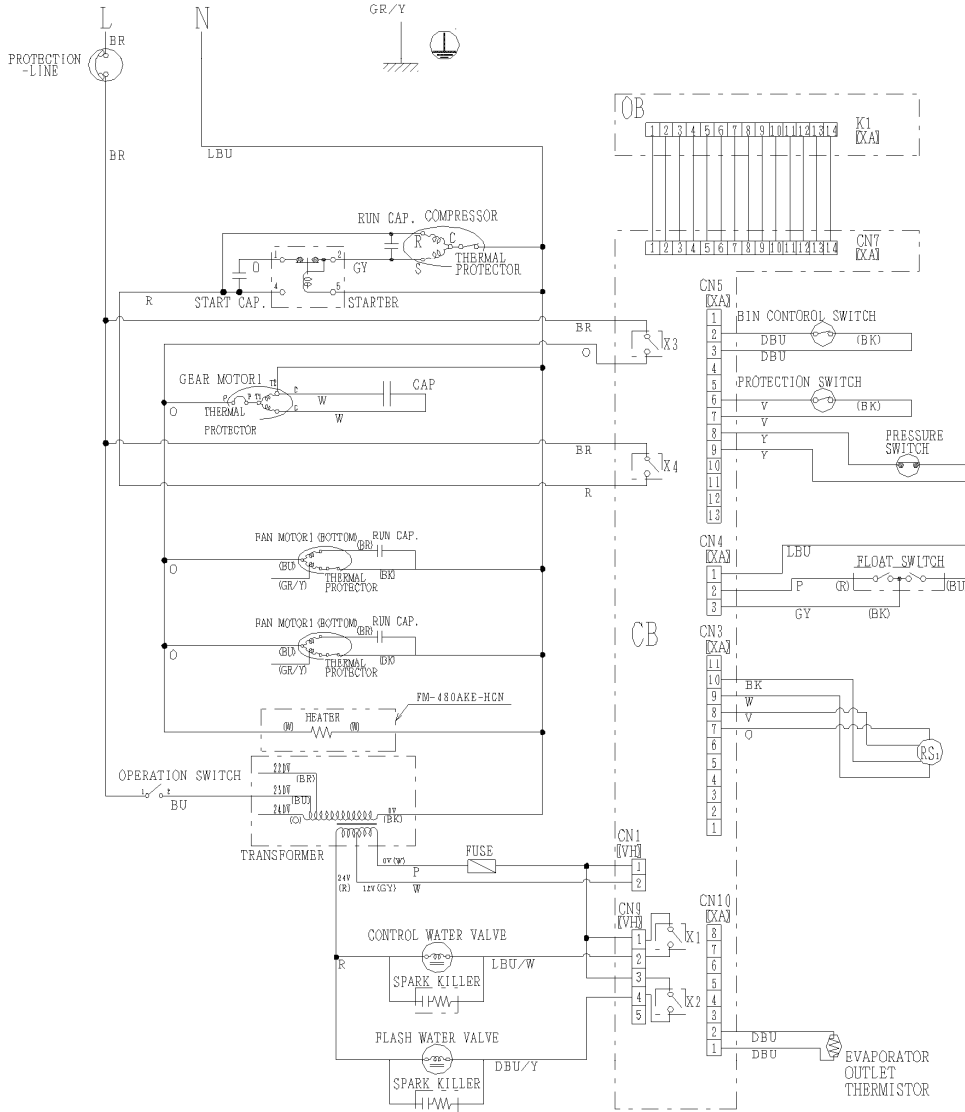

ERROR TABLE

E0, C0	ICEMAKING WATER LEAK
E1	LOW ICE PRODUCTION
E2	FLOAT SWITCH ERROR
E3, E8	GEAR MOTOR ERROR
c2	ABNORMAL HIGH SIDE PRESSURE
E5	GEAR MOTOR DRIVE ELEMENT ERROR
EF	FREQUENT VOLTAGE ERROR
EL	BIN CONTROL SWITCH ERROR
EP	MODEL NUMBER ERROR
EU	CONTROLLER BOARD ERROR
c1	LOW WATER
c3	ABNORMAL LOW VOLTAGE
c4	DRAIN ERROR

WIRE COLOR CODE

O	ORANGE
R	RED
BU	BLUE
DBU	DARK BLUE
BR	BROWN
GY	GRAY
LBU	LIGHT BLUE
P	PINK
Y	YELLOW
V	VIOLET
BK	BLACK
W	WHITE

FM-480AKE-HC(N) (Auxiliary code: D-1 or later)

SET No.
18

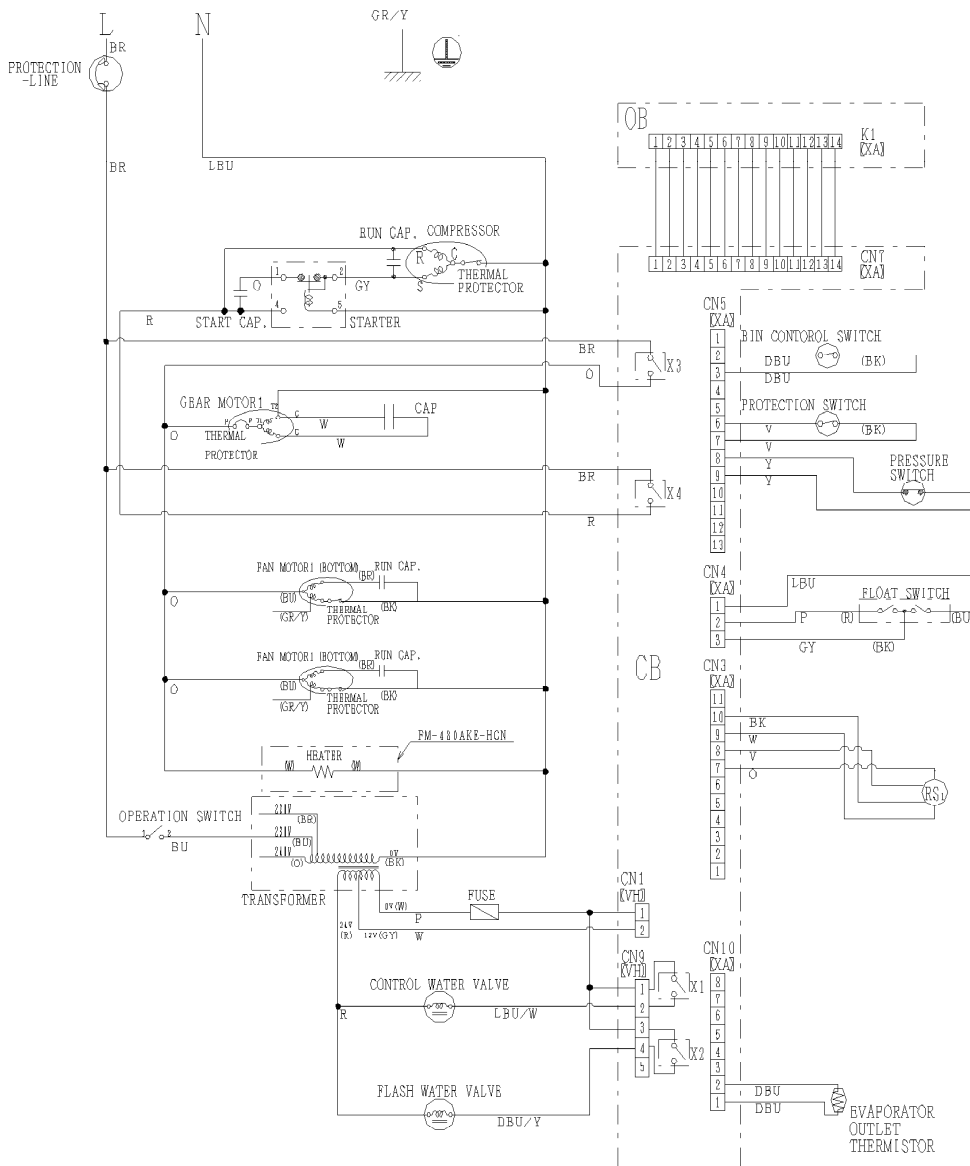

WIRE COLOR CODE

O	ORANGE
R	RED
BU	BLUE
DBU	DARK BLUE
BR	BROWN
GY	GRAY
LBU	LIGHT BLUE
P	PINK
Y	YELLOW
V	VIOLET
BK	BLACK
W	WHITE

[b] CONTROL BOX LAYOUT

FM-300AKE-HC(N), FM-480AKE-HC(N)

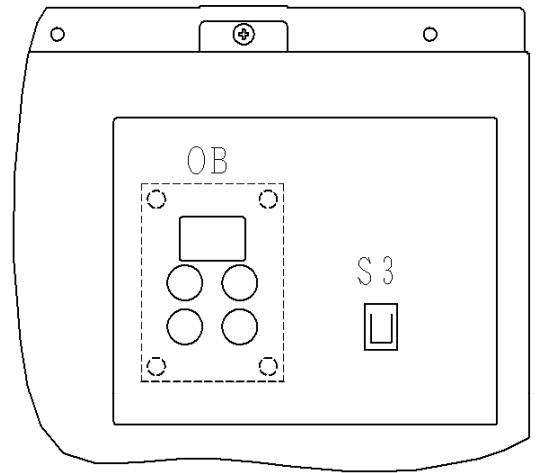
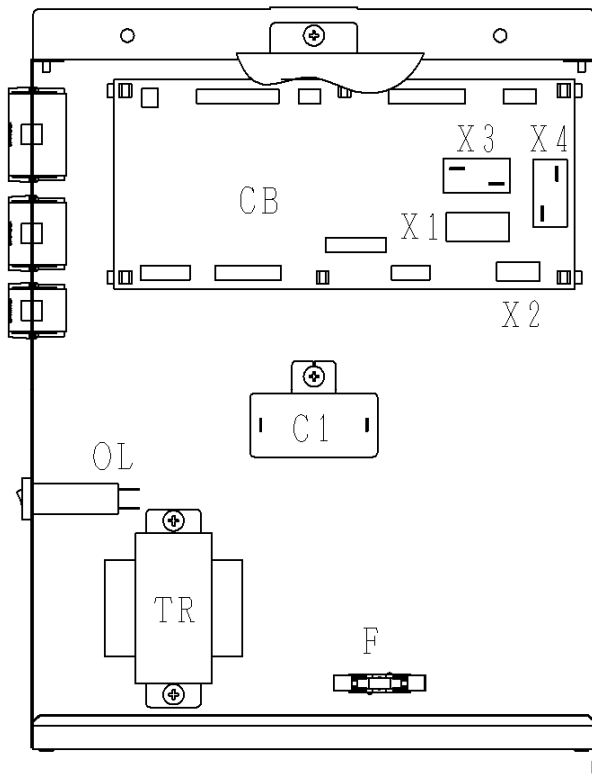

CB	CONTROLLER BOARD-MAIN
OB	CONTROLLER BOARD-OPERATION
X1	POWER RELAY (CONTROL WATER VALVE, ON BOARD)
X2	POWER RELAY (FLUSH WATER VALVE, ON BOARD)
X3	POWER RELAY (GEAR MOTOR, ON BOARD)
X4	POWER RELAY (COMPRESSOR, ON BOARD)
S3	OPERATION SWITCH
OL	CIRCUIT PROTECTOR (10A: 300AKE-HC / 20A: 480AKE-HC)
C1	CAPACITOR (GM1)
F	FUSE 3.15A
TR	TRANSFORMER

3. ICEMAKING MECHANISM

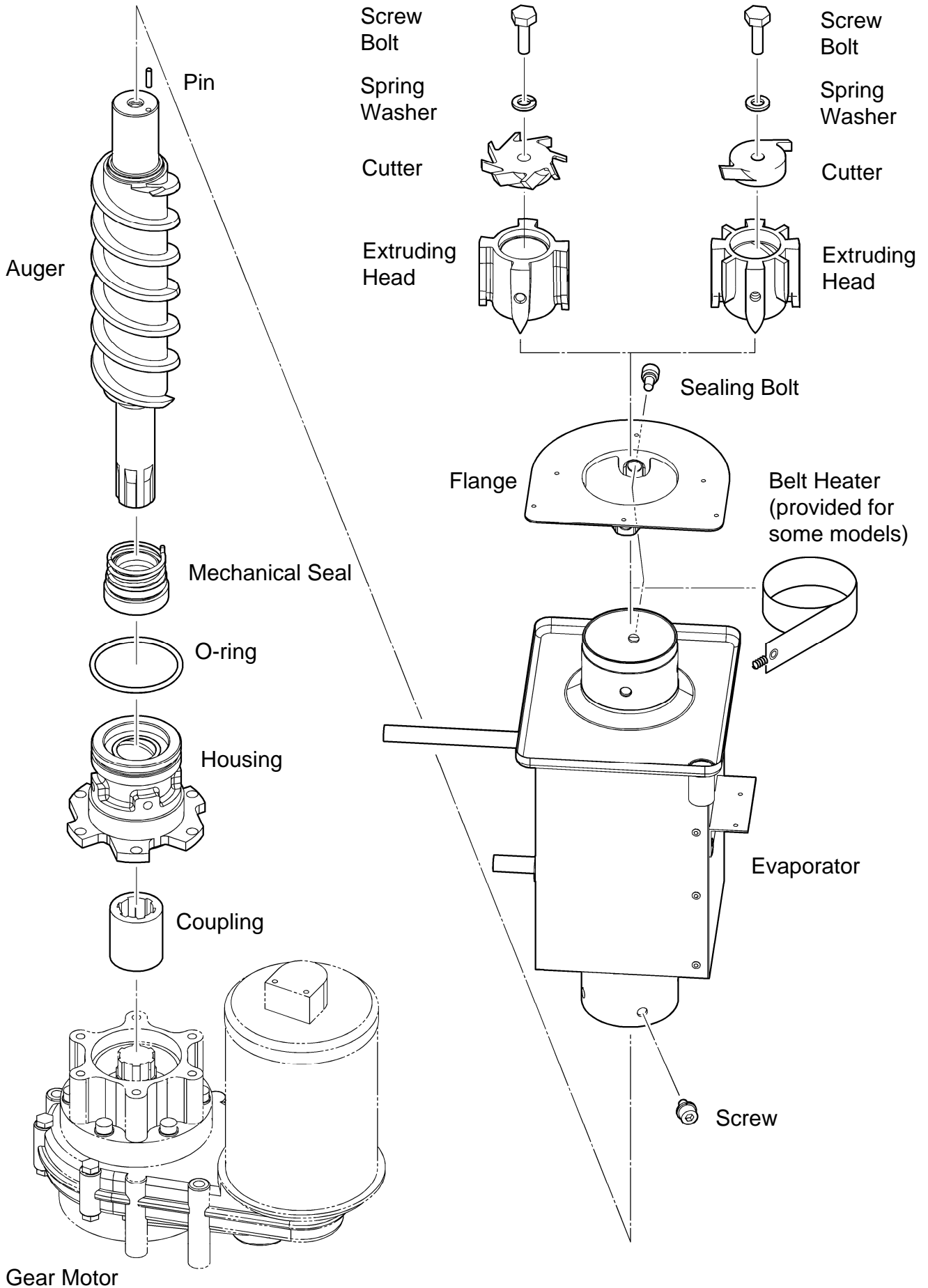

[a] EVAPORATOR (CASING)

The evaporator consists of a stainless steel icemaking cylinder coiled with a refrigeration pipe and wrapped together with a polyurethane foam insulation material. Water coming from the inlet into the evaporator will be frozen into ice. The ice spout is located on top of the evaporator.

[b] AUGER

The stainless steel auger is supported by the upper and lower bearings of the evaporator and slowly rotated by the gear motor, while scraping off the ice forming on the inner wall of the cylinder and pushing up to the ice spout.

[c] EXTRUDING HEAD (BEARING)

The stainless steel extruding head is provided with a press-fit plastic bearing inside and fixed on top of the evaporator. The extruding head functions as the auger bearing and compresses the sherbet ice carried up by the auger into a column shape with the path resistance.

[d] HOUSING

The cast bronze housing is provided with a press-fit plastic bearing inside and fixed on the bottom of the evaporator for connection with the gear motor.

[e] MECHANICAL SEAL

The mechanical seal on the lower auger bearing prevents icemaking water leaks into the evaporator. The mating surfaces are made of ceramic and carbon.

[f] COUPLING (SPLINE JOINT)

The auger bottom and gear motor output shaft are splined and connected with the spline joint.

[g] GEAR MOTOR

The gear motor consists of a 200W 1 phase 240V or 80W 1 phase 220 - 240 / 220V drive motor integrated with a decelerator and provided with a built-in auto-reset thermal protector. When the thermal protector trips, the controller board will stop the gear motor. The thermal protector trips when the gear motor mechanism is overloaded or when excessively high or low voltage is applied on the gear motor. The electrical capacity must be increased if a large current flows through the surrounding equipment.

[h] BELT HEATER (provided on some models)

The belt heater is provided to reduce the load of ice passing the extruding head during a freeze cycle and to prevent vapor lock during a flush cycle.

[i] REMOVABLE FLANGE

The flange used to be welded on the evaporator to fix the spout. But sometimes the extruding head applies excessive load on the evaporator to compress ice, resulting in breaking the welded joints. To avoid the load, the flange has been changed to a separate part to be secured together with the extruding head by using sealing bolts.

[j] SEALING BOLT

Sometimes the icemaking operation may produce white solids on the drip pan. They are deposits of silica and calcium contents in the icemaking water leaking from the sealing bolt. The bolt is provided with retaining and sealing functions, which may be reduced by the load and vibration during a freeze cycle. Do not reuse a removed sealing bolt.

Solids deposited from
sealing bolt



[K] BIN CONTROL SWITCH (Auxiliary code: D-0 or earlier)

The bin control switch is composed of a proximity switch and actuator. When the chute fills up, ice will push up the actuator on top of the chute to switch off the proximity switch. After 7 seconds, the controller board will stop the gear motor and compressor at the same time. When ice is used, the actuator will return to the original position to switch on the proximity switch. The gear motor will restart in 7 seconds, and the compressor in 5 minutes.

When the bin control switch seems to have malfunctioned, check the dimensions of the actuator as well as the operation of the proximity switch. Also, if the chute switch or the gear motor circuit protector has operated for some unidentified reason, be sure to check the actuator for proper dimensions.

- 1) Remove the bin control switch from the chute.
- 2) Move the actuator to the maximum operation angle as shown below (top). Check that the actuator is about 13 mm away from the barrier. If not, replace the whole bin control switch assembly.

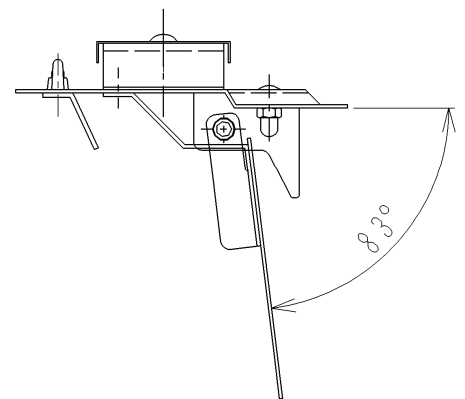
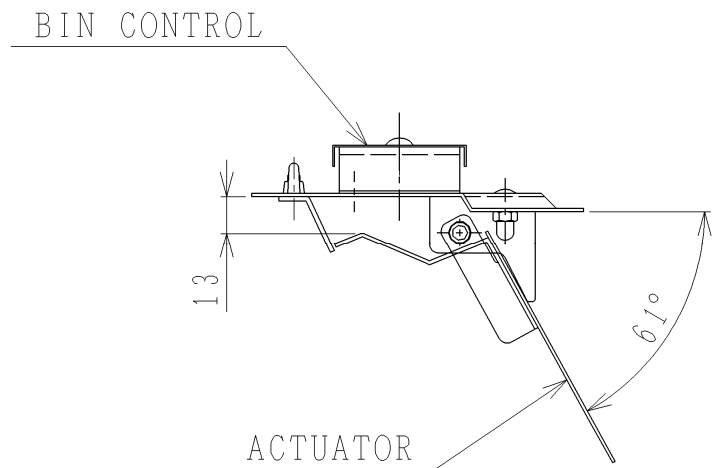

[I] BIN CONTROL SWITCH (Auxiliary code: D-1 or later)

The bin control switch is composed of a reed switch attached to the spout and an actuator (ice detector) provided inside the spout and chute.

The bin control switch operates as follows:

1. Ice reaches up to the ice detector.
2. Ice pushes and moves the ice detector.
3. The actuator magnet shifts and departs from the reed switch
4. The reed switch turns off.
5. The icemaking operation stops.

Heavy soil inside the spout or chute may cause ice to get stuck. Dirty actuator hinge may disturb the movement of actuator. Check the cleanness of spout, chute, and actuator at periodic inspection or periodic part replacement. Wipe clean any notably dirty part.

The ice detector is different for flake icemaker and nugget icemaker. If incorrect detector is attached, the bin control function will not work. If the icemaking operation continues, the abnormal stop switch trips and the unit stops with an error. Be sure to attach the proper ice detector. The actuator is composed of two components bonded. The letters "C" and "F" are stamped on the fitting part. The type of icemaker can be distinguished by boss fitting position.

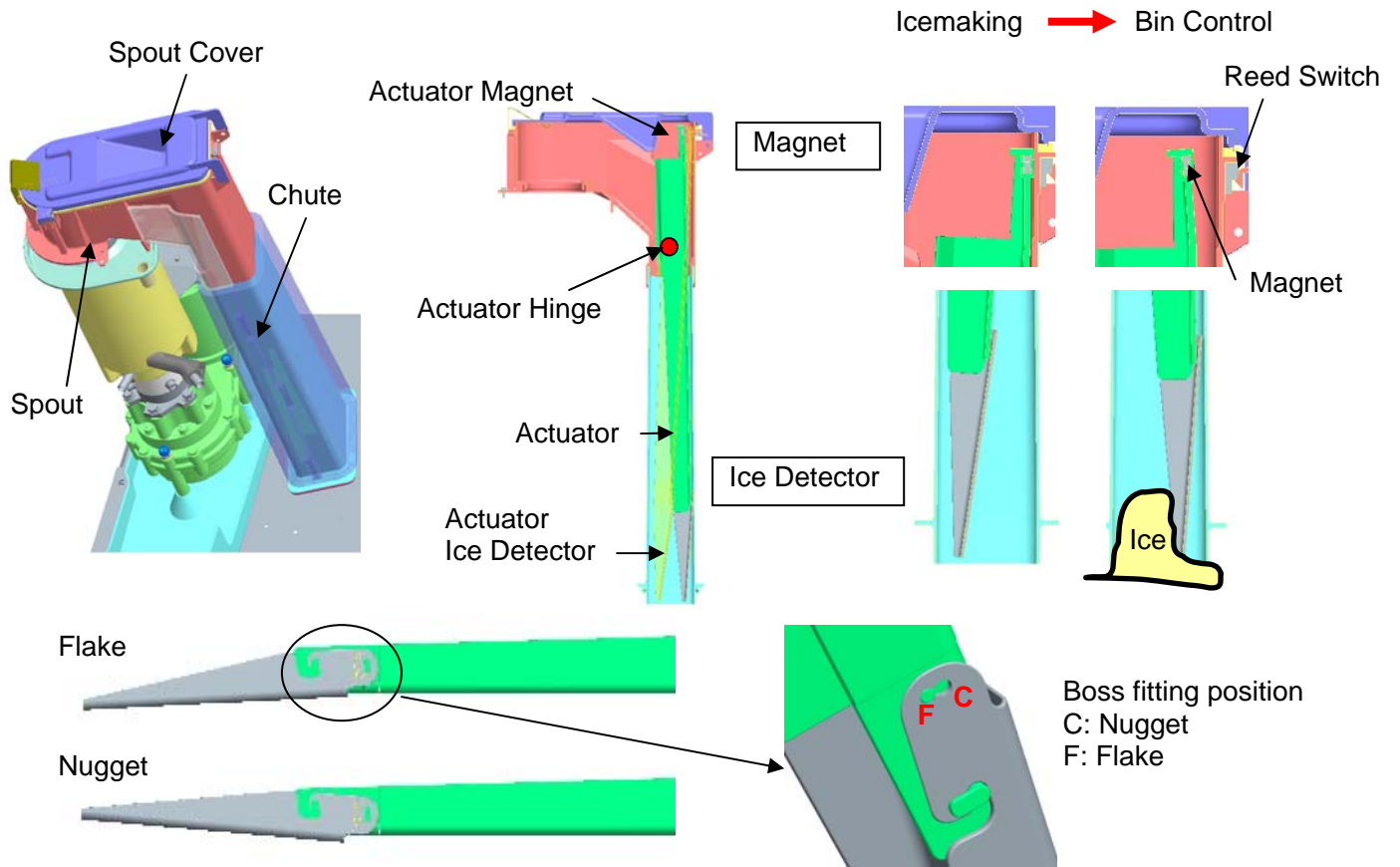

[m] CHUTE SWITCH (Auxiliary code: D-0 or earlier)

The chute switch consists of a microswitch and a band securing the spout and chute. When the bin control switch breaks down, the band opens and presses the button on the microswitch (contacts open) to stop the icemaker (error code: EL).

To restart the icemaker, remove ice from the spout and chute, and move the operation switch to the "STOP" position, then to the "RUN" position.

Normal Condition

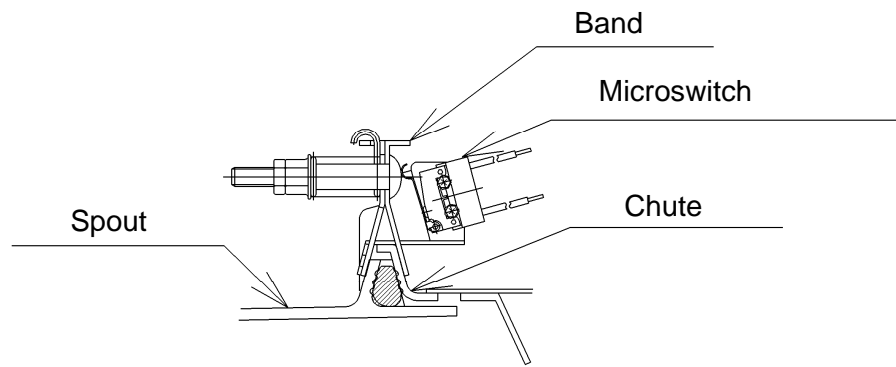

**Abnormal Condition
(Band moves and presses microswitch)**

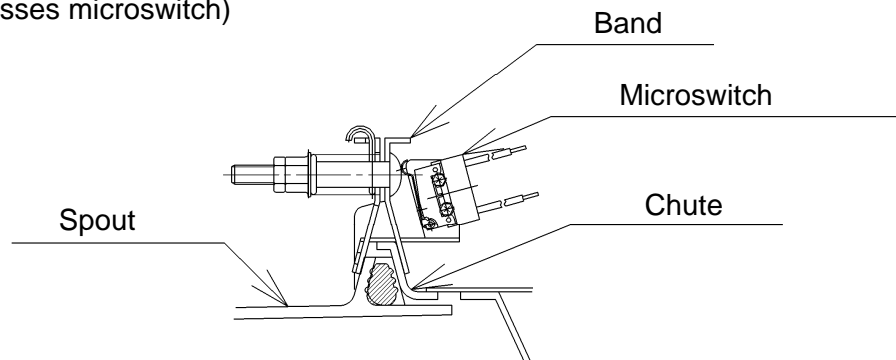

[n] SPOUT, SPOUT COVER (Auxiliary code: D-1 or later)

The spout and spout cover are connected to the evaporator casing with a removable flange. These are the passage to deliver ice formed inside the evaporator casing into the chute. The spout is provided with a reed switch, and the spout cover with a magnet. If the bin control switch goes wrong and fails to stop icemaking operation with the bin full, ice pushes up the spout cover, and the magnet gets away from the reed switch to stop the unit.

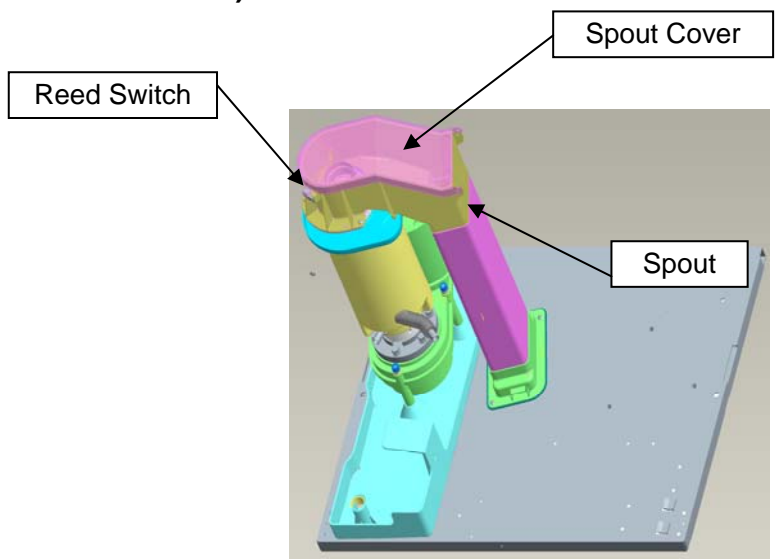

[b] TIMING CHART

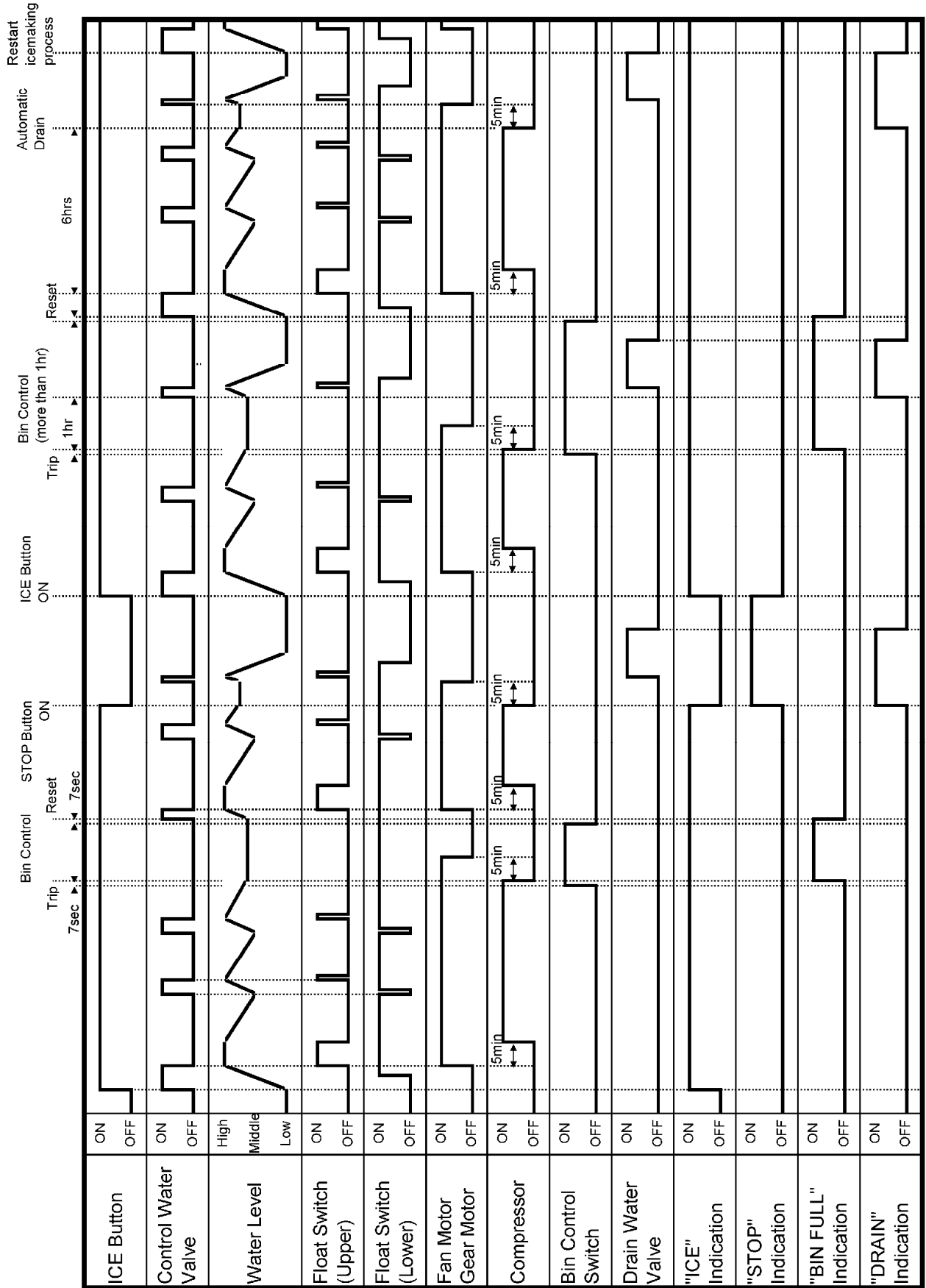

5. OPERATION BOARD

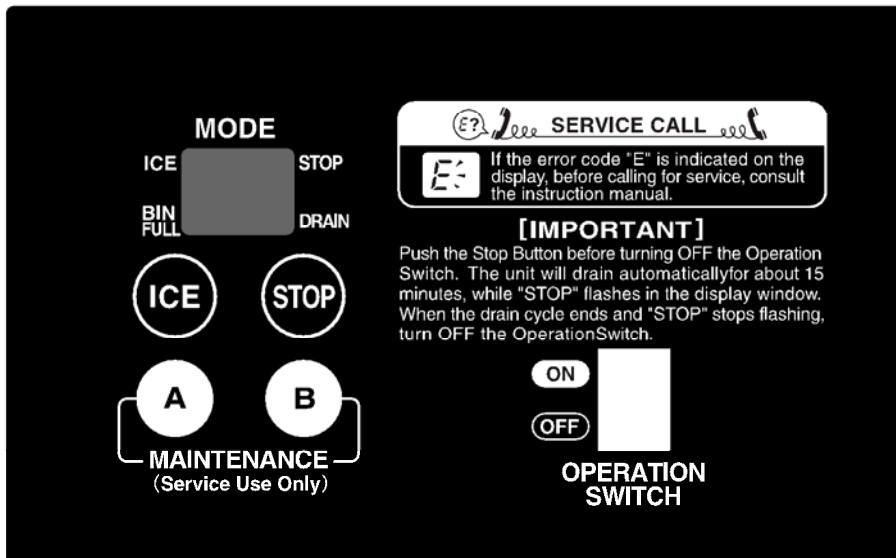

[a] OPERATION BUTTONS

ICE = When pressed in the STOP mode, the unit is supplied with water and starts icemaking operation.

STOP = When pressed in the ICE mode, the unit stops icemaking operation and drains.

MAINTENANCE A = Used for various maintenance operations.

MAINTENANCE B = Used for model code setting.

OPERATION SWITCH = Power supply for the icemaker. Move it to the "OFF" position to shut down the unit for a long time.

[b] SETTING MODEL NUMBER

The model number must be set at the time of replacement of the controller board. Check the model number specified on the wiring label. Improper setting may result in failure or inoperability.

- 1) Press and hold the maintenance B button, and move the operation switch to the "ON" position.
- 2) When the display shows "99", release the maintenance B button.
- 3) Press the stop button to increase the number, or press the ice button to decrease the number until it matches the model number on the wiring label.
- 4) Press the maintenance B button to complete the setting and start icemaking operation in the ice mode.
- 5) To check the model number, see next page.

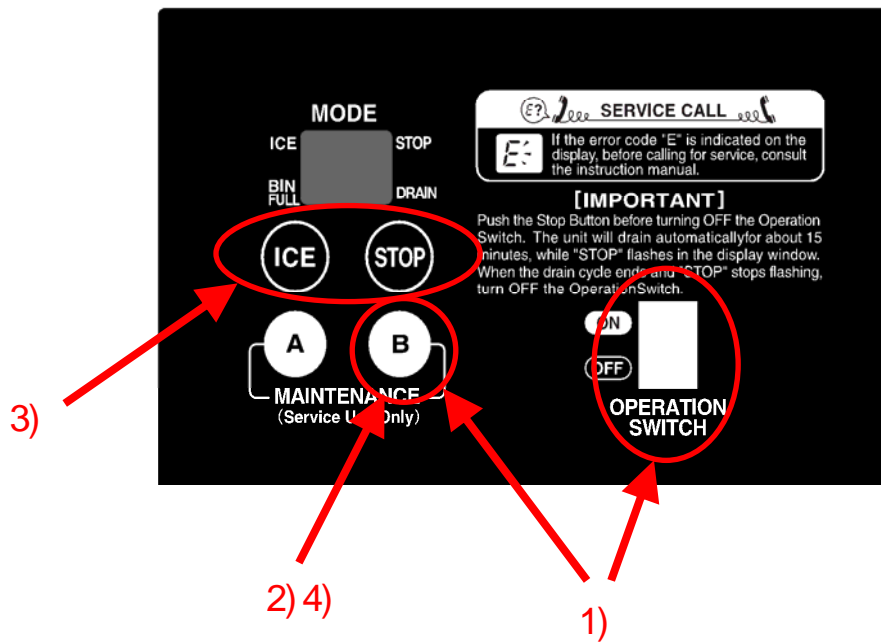

[c] DISPLAYING COMPRESSOR OPERATING HOURS, CYCLE TIME, MODEL NUMBER AND SOFTWARE VERSION

Press and hold the maintenance A button, and press the ice button. The display shows the following items one by one every time the ice button is pressed. This function is available in the ice or stop mode.

- Press and hold **MAINTENANCE A**
- ↓ **Compressor operating hours** on display ----- a)
 - Press **ICE**
 - ↓ **Cycle time** on display ----- b)
 - Press **ICE**
 - ↓ **Model number** on display ----- c)
 - Press **ICE**
 - ↓ **Software version** on display ----- d)
- Release **MAINTENANCE A**

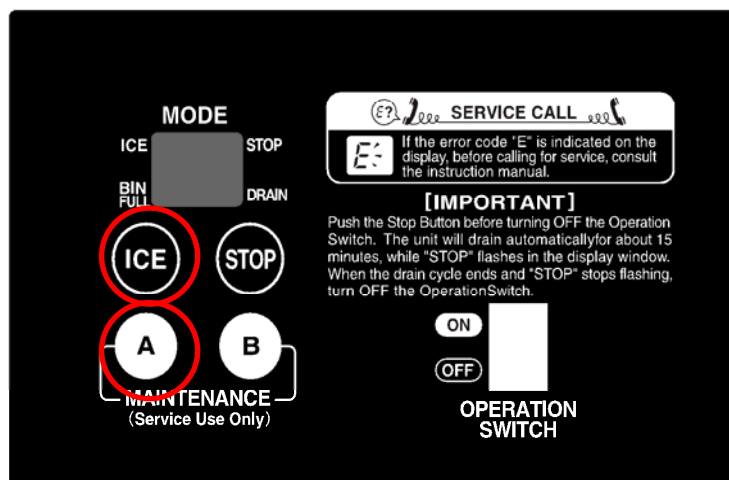

Note:

1. The display shows the next item if the ice button is pressed before one item appears in the display.
2. The display mode is cancelled if the maintenance A button is released.
3. The software version is displayed repeatedly while the maintenance A button is pressed. Release the maintenance A button to cancel the display mode.

a) Compressor Operating Hours

The display shows the compressor operating hours in six digits divided into three parts (2 digits for 2 seconds each time).

Then, “- -” appears in the display (to show the end of the compressor operating hours display mode).

e.g. 3527 hours = “00”, “35”, “27”, “- -”

b) Cycle Time

The display shows the cycle time in four digits divided into two parts (first minutes then seconds, for 2 seconds each time) from the latest record (5 records at maximum).

Then, “- -” appears in the display (to show the end of the cycle time display mode).

If no cycle time is recorded, the display shows “- -” only.

Minutes are indicated as follows:

0	0 to 9	= 0 to 9 minutes
A	0 to 9	= 10 to 19 minutes
b	0 to 9	= 20 to 29 minutes
D-0	0 to 9	= 30 to 39 minutes
d	0 to 9	= 40 to 49 minutes
E	0 to 9	= 50 to 59 minutes

Seconds are indicated as 0 to 5 | 0 to 9.

e.g. 09 | 48 = 9 minutes 48 seconds b7 | 36 = 27 minutes 36 seconds

By using the freeze cycle time, **approximate ice production capacity** can be calculated.

Series	Approximate ice production capacity (kg/d)
FM-300	60,000 / cycle time (sec)
FM-480	

This is just an approximate capacity. The actual capacity depends on ambient temperature, water temperature, voltage and frequency.

For accurate measurement, use a container to receive ice actually produced for 10 minutes, measure its weight, and calculate ice production per day. Repeat this three times to figure out the average.

c) Model Number

The display shows two digits.

e.g. FM-480AKE-HC(N) = “18”

d) Software Version

The display shows the software version in six digits/symbols divided into three parts.
 e.g. Ver. 9-3-6 = "09", "-3", "-6"
 The indication is repeated until the maintenance A button is released.

[d] DISPLAYING ERROR LOG

Press and hold the maintenance A button, and press the stop button. The display shows the following items one by one every time the stop button is pressed. This function is available in the ice or stop mode.

- Press and hold **MAINTENANCE A**
- Press **STOP** → **Compressor operating hours** on display ----- **[c] a)**
 - Press **STOP** → **Error log** on display (8 records at maximum)
 - Press **STOP** → "- -" on display (end of error log display mode)
 - Press **STOP** → **Ongoing error** on display
- Release **MAINTENANCE A**

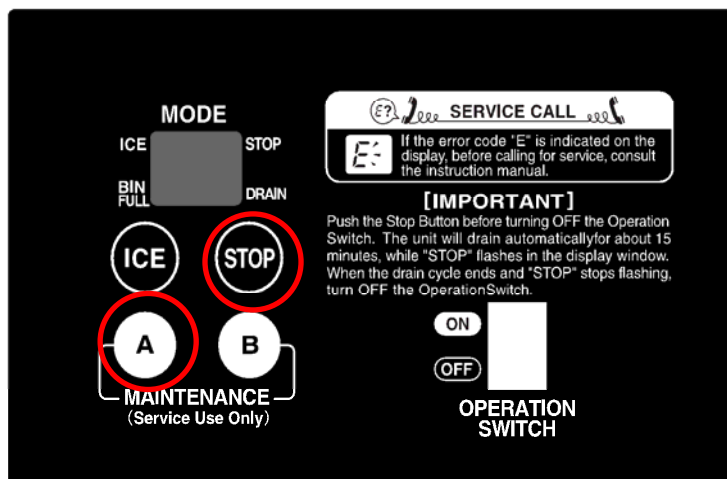

Note:

1. The display does not show the ongoing error even if the stop button is pressed while the error log is in the display. To display the ongoing error, press the stop button while "- -" is in the display to show the end of the error log display mode

[e] RESETTING ERROR LOG

With the operation switch in the “OFF” position, press and hold the stop and maintenance A buttons. Move the operation switch to the “ON” position. Release the buttons when the display shows the ice mode. Now the error log is reset. Do not reset more than necessary.

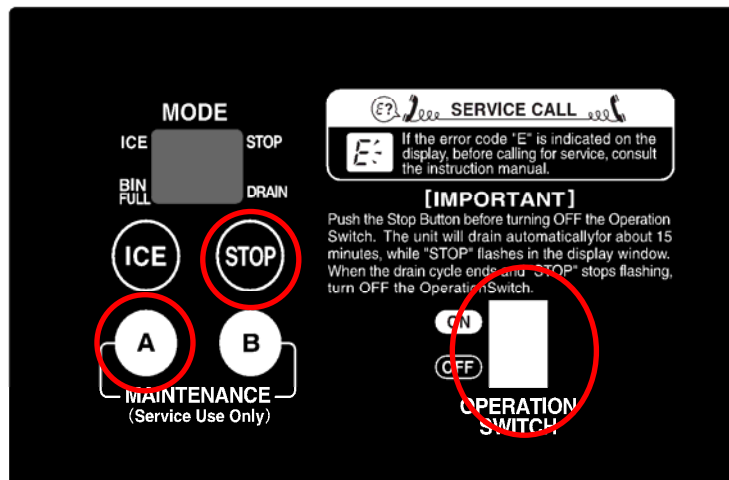

[f] RESETTING COMPRESSOR OPERATING HOURS

With the power switch turned off, press and hold the ice, stop and maintenance A buttons. Move the operation switch to the “ON” position. Release the buttons when the display shows the ice mode. Now the compressor operating hours are reset.

When the compressor starts in 15 seconds after the water supply cycle ends, the error log is not set to be updated. After resetting the compressor operating hours, move the operation switch to the “OFF” position, turn off the power switch, and turn it back on.

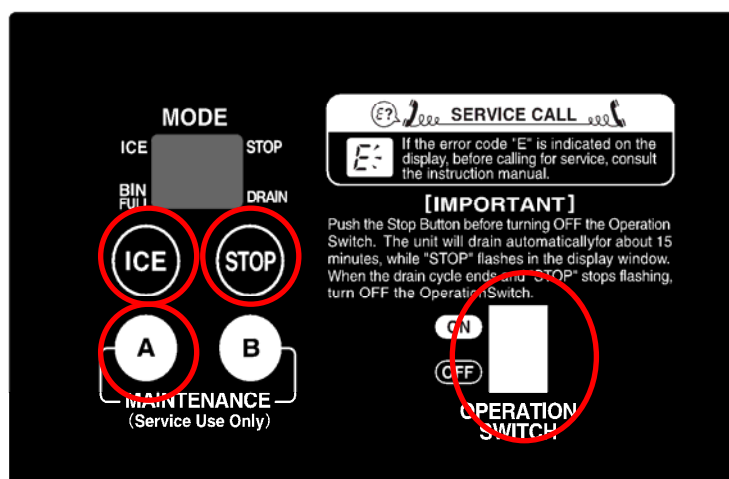

[g] REDUCING COMPRESSOR STARTING TIME

With the power switch turned off, press and hold the maintenance A button. Move the operation switch to the "ON" position. Release the button when the display shows the ice mode.

The compressor starts in 30 seconds after the water supply cycle ends

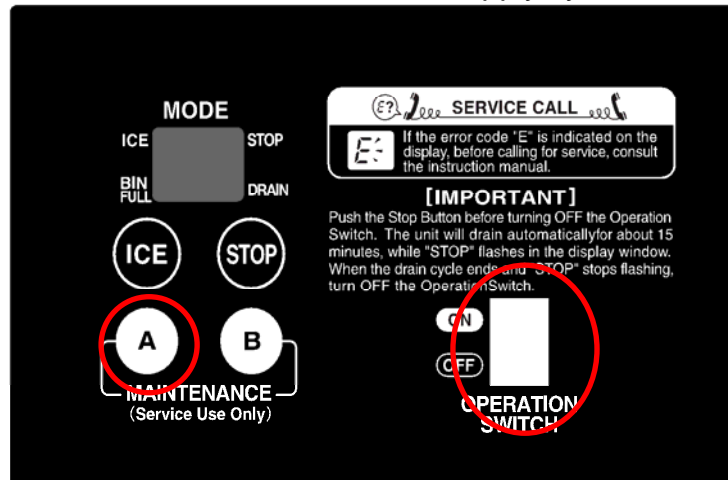

6. PROTECTORS

[a] INDICATION

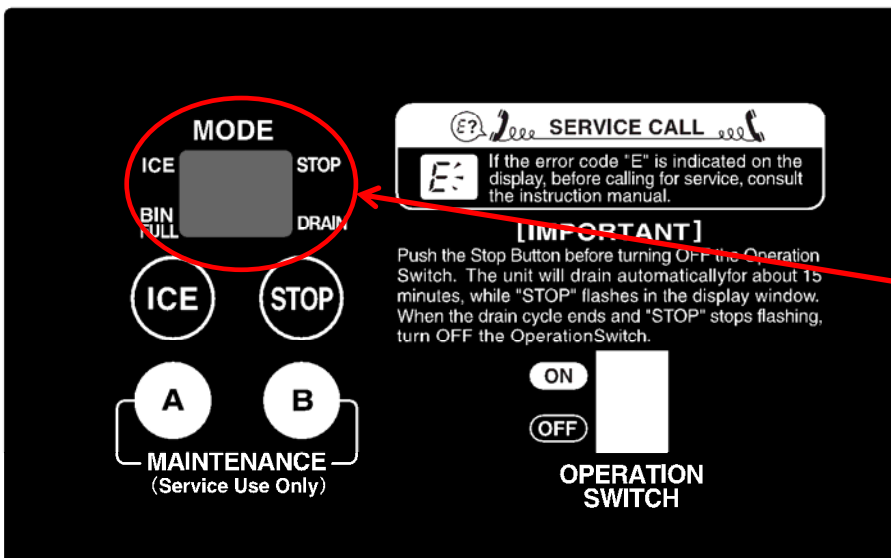

When an operational error occurs, "E_" will appear and blink in the display on the operation board, and the icemaker will stop. When a service call is received, ask the user to check which error code is in the display. Then, see the error code table in "7. ERROR CODES" to locate the cause.

7. ERROR CODES

Interlock Errors

Code	Error	Condition	Operation	Reset	Check/Repair
E0	Icemaking Water Leak	c0 error occurs 2 times in a row.	Whole unit stops.	Power supply, Turn OFF - Turn ON	Water leak from water circuit (reservoir, inlet hose, outlet hose, hose joint, mechanical seal, flush water valve), float switch
E1	Low Ice Production	Icemaking cycle takes too long.	Whole unit stops.	Power supply, Turn OFF - Turn ON	Gas leak, control water valve not closing, vapor lock, freeze, float switch
E2	Float Switch Error	With flush water valve OFF, float switch trips at both upper and lower float levels for 2 seconds.	Whole unit stops.	Power supply, Turn OFF - Turn ON	Float switch
E3	Gear Motor Error or Gear Motor Sensor Circuit Open	Gear motor is ON with rotation sensor or current sensor circuit open.	Whole unit stops.	Power supply, Turn OFF - Turn ON	Rotation sensor, current sensor
		Gear motor relay is ON with gear motor protective circuit detector OFF.			Gear motor protective circuit (TPO, overload, etc.), gear motor relay
E4	Abnormal High Side Pressure	c2 error occurs 5 times in 1 hour of compressor operation.	E4 blinks.	N/A	Fan motor, cooling water circuit, refrigeration circuit, condenser clogged, water supply, installation conditions
E5	Gear Motor Drive Element Error	Gear motor is OFF on controller board while rotation sensor signals gear motor rotation or current flows.	Whole unit stops.	Power supply, Turn OFF - Turn ON	Miswiring, gear motor magnet switch or relay Replace controller board.
		Gear motor relay is OFF with gear motor protective circuit detector ON.			
E8	Discharge Pipe Temperature Error	Discharge pipe thermostat is OFF.	Whole unit stops.	Power supply, Turn OFF - Turn ON	Gas leak, compressor cooling fan failure
EA	Water Thermistor Circuit Open	Water thermistor circuit is open.	EA blinks.	N/A	Water thermistor
Eb	Condenser Thermistor Circuit Open	Condenser thermistor circuit is open.	Whole unit stops.	Power supply, Turn OFF - Turn ON	Condenser thermistor
EC	Evaporator Outlet Thermistor Circuit Open	Evaporator outlet thermistor circuit is open.	Whole unit stops.	Power supply, Turn OFF - Turn ON	Evaporator outlet thermistor
EE	Gear Motor Error	Rotation sensor detects reversing.	Whole unit stops.	Power supply, Turn OFF - Turn ON	Gear motor locked, hunting or overloaded, supply voltage, high ambient temperature
		c5 error occurs 5 times.			
EF	Abnormal Low Voltage	c3 error occurs 3 times in 24 hours.	Whole unit stops.	Power supply, Turn OFF - Turn ON	Supply voltage
EH	Discharge Pipe Thermistor Circuit Open	Discharge pipe thermistor circuit is open.	EH blinks.	N/A	Discharge pipe thermistor
EL	Bin Control Switch Error	Bin control protective switch trips.	Whole unit stops.	Power supply, Turn OFF - Turn ON	Bin control switch

Code	Error	Condition	Operation	Reset	Check/Repair
En	Low Voltage Sensing Transformer Circuit Open	Low voltage sensing transformer circuit is open.	Whole unit stops.	Power supply, Turn OFF - Turn ON	Low voltage sensing Transformer
EU	Controller Board Error	Controller board IC fails.	Whole unit stops.	Power supply, Turn OFF - Turn ON	Replace controller board.
None	Electric Leak Short Circuit	Electric leak or overcurrent.	Whole unit stops.	Power supply, Turn OFF - Turn ON Replace fuse	Electric leak, fuse

Non-Interlock Errors

Code	Error	Condition	Operation	Reset	Check/Repair
CM Time "-."	Microcomputer Read/Write Error	Microcomputer fails to read/write properly.	Memory circuit not available.	Replace controller board.	Error records and compressor operating hours not available on display
c0	Icemaking Water Leak	After initial water supply, float switch trips at lower float level within 5 minutes after gear motor starts and before compressor starts.	Whole unit stops. Flush water valve turns ON for 1 second, then turns OFF. Unit restarts.	Error record only.	Water leak from water circuit (reservoir, hoses, mechanical seal, flush water valve), float switch
c1	Low Water	Water supply continues for more than 90 seconds, or float switch trips at lower float level and does not reset for more than 60 seconds after water supply.	Whole unit stops until reservoir fills up. Only control water valve operates intermittently for 5 minutes.	Automatically resets after reservoir fills up.	Water supply interruption, control water valve not opening, flush water valve not closing, float switch, water leak
c2	Abnormal High Side Pressure	Pressure switch stays OFF for 5 seconds or condenser thermistor reads higher than set point for 5 seconds.	Whole unit stops.	Automatically resets after pressure switch turns ON or condenser thermistor reads lower than set point.	Condenser clogged, cooling water circuit, refrigeration circuit
c3	Abnormal Low Voltage	Voltage stays below setting for more than 1 second with compressor ON and control water valve OFF.	Whole unit stops.	Automatically resets after voltage stays above reset setting for 2 minutes.	Supply voltage
c4	Drain Error	Float switch trips at upper float level in 10 minutes after flush water valve turns ON.	N/A	Error record only.	Flush water valve not opening, control water valve not closing
c5	Gear Motor Error	Rotation rate reduces. While gear motor is running, voltage detection signal is not input to controller board.	Whole unit stops.	Automatically resets after 30 minutes.	Gear motor overloaded
c7	Evaporator Outlet Temperature Decrease	Evaporator outlet temperature decreases.	Indication only.	Automatically resets.	Evaporator inside not clean, extruding head not clean, heater circuit open

8. PERFORMANCE DATA

[a] FM-300AKE-HC

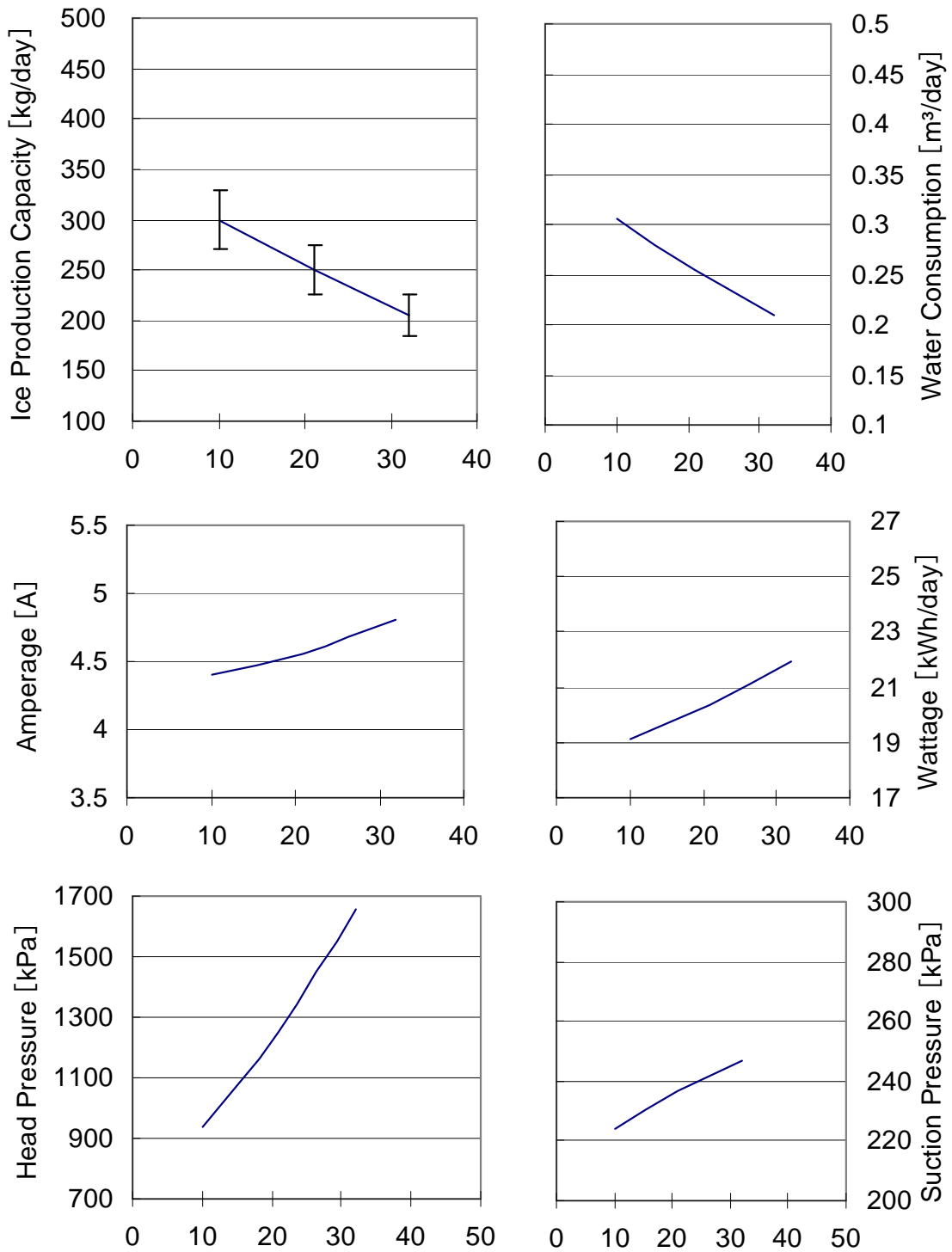

The horizontal axis shows the ambient temperature.
It refers to the data of at/wt=10/10, 21/15, 32/21.

[b] FM-300AKE-HCN

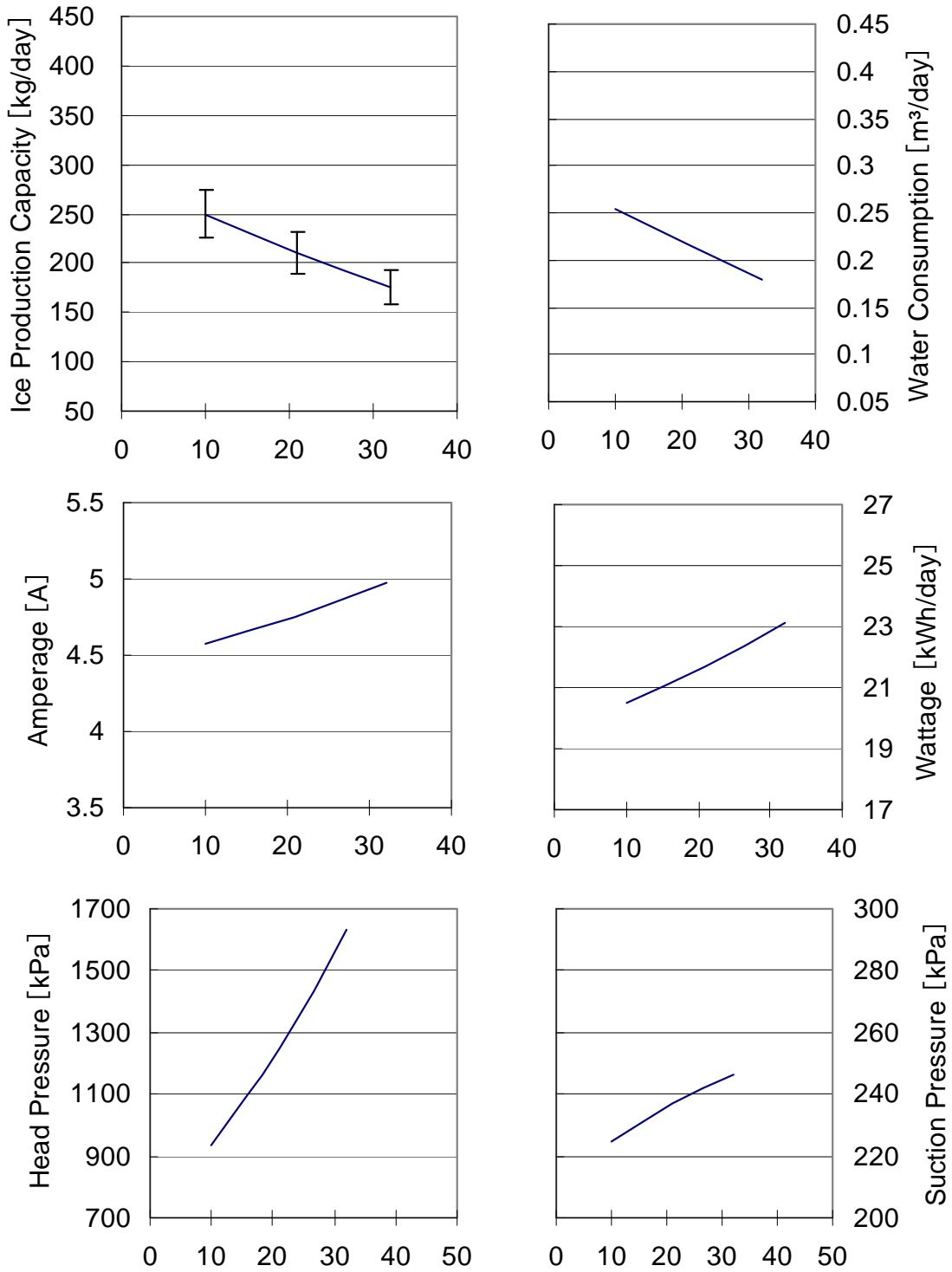

The horizontal axis shows the ambient temperature.
It refers to the data of at/wt=10/10, 21/15, 32/21.

[c] FM-480AKE-HC

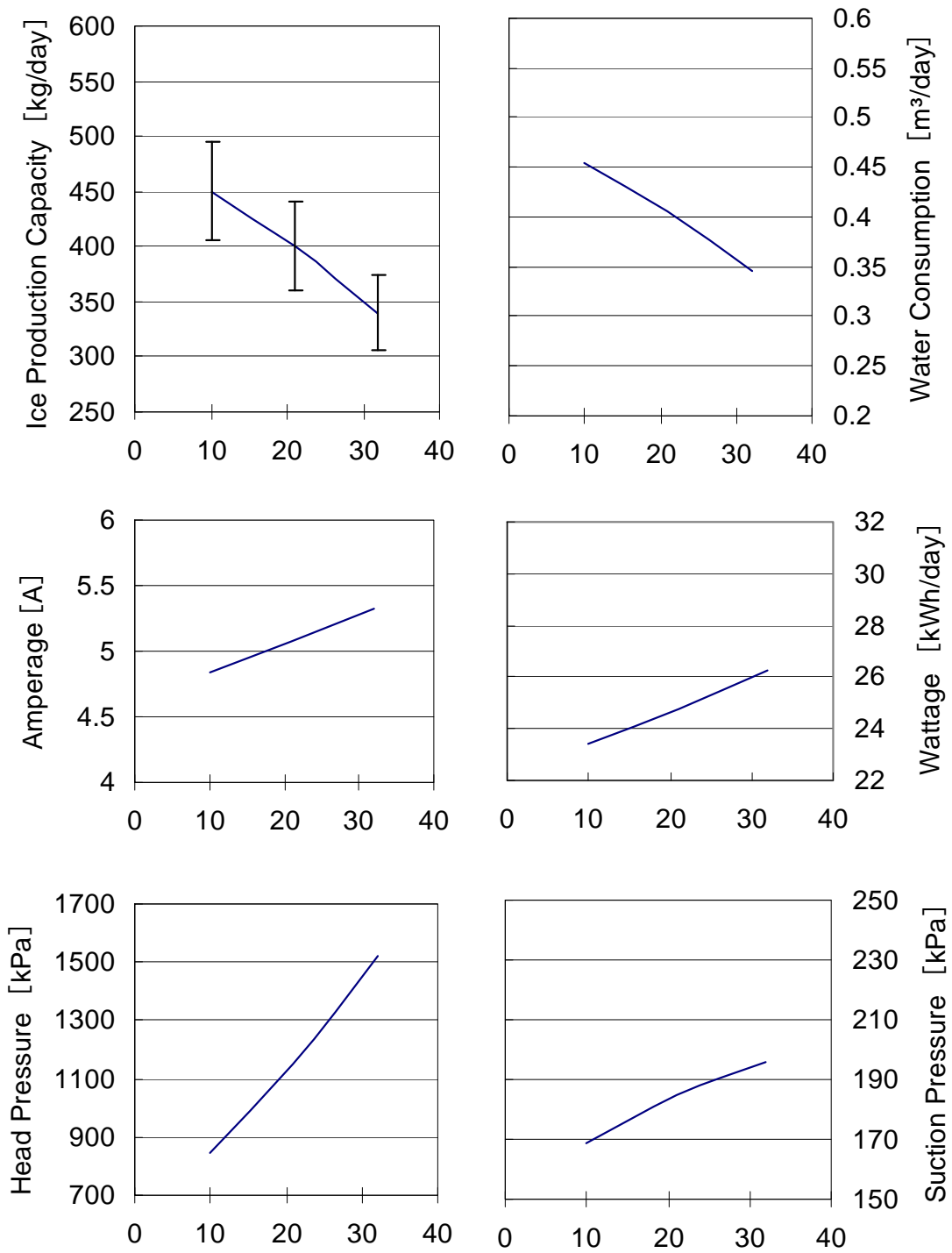

The horizontal axis shows the ambient temperature.
 It refers to the data of at/wt=10/10, 21/15, 32/21.

[d] FM-480AKE-HCN

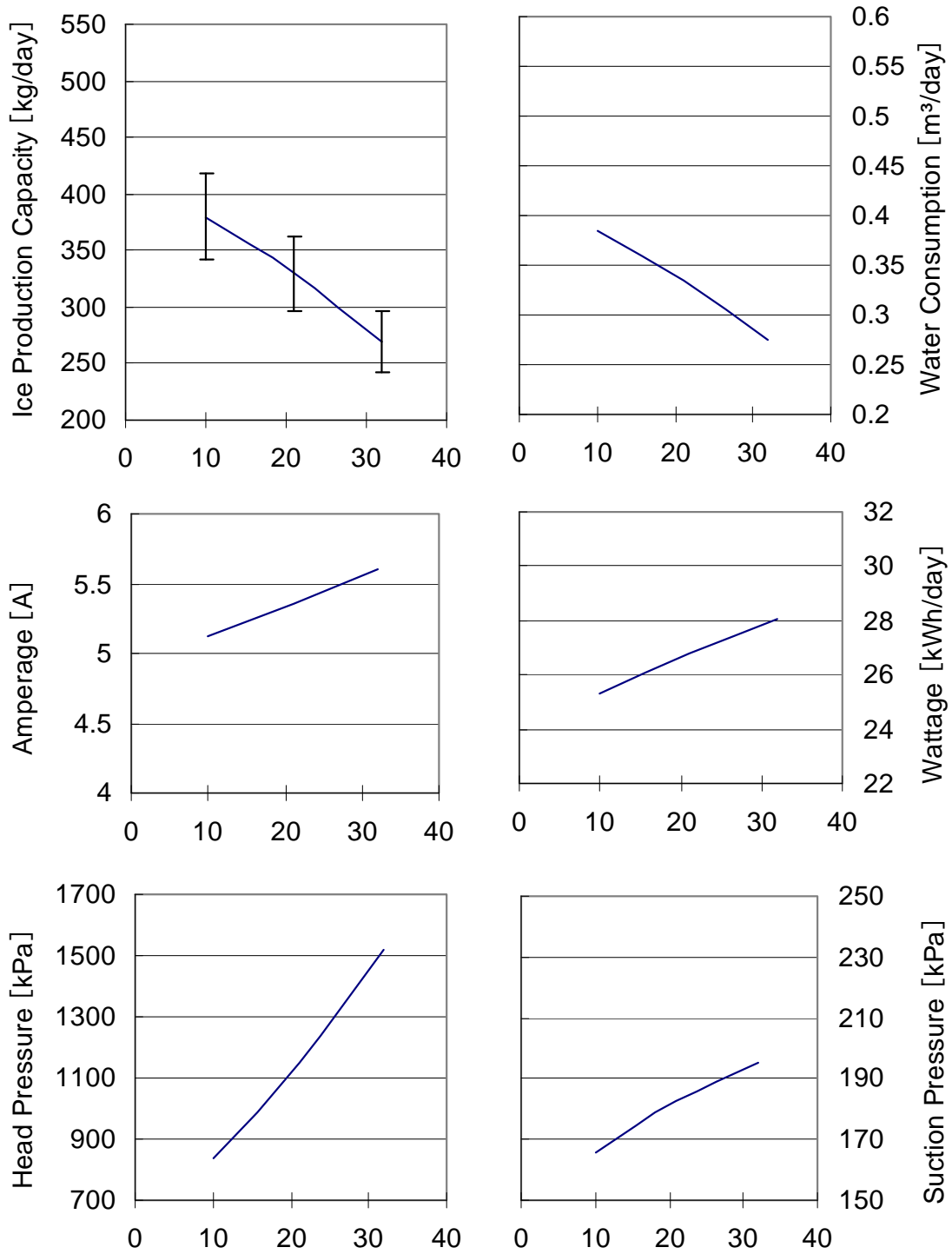

The horizontal axis shows the ambient temperature.
It refers to the data of at/wt=10/10, 21/15, 32/21.

IV. SERVICE DIAGNOSIS

Display error records by operating the operation board (see “III. 5. [d] DISPLAYING ERROR LOG”). Check for a possible cause and service the unit.

1. NO ICE PRODUCTION

PROBLEM	POSSIBLE CAUSE		REMEDY
[1] The icemaker will not start.	a) Power supply	1. OFF position.	1. Move to ON position.
		2. Loose connections.	2. Tighten.
		3. Bad contacts.	3. Check for continuity and replace.
		4. Blown fuse.	4. Replace.
		5. Voltage too low.	5. Get recommended voltage.
	b) Fuse	1. Blown out. No indication on operation board.	1. Locate and resolve the cause of short circuit (ex. control water valve, flush water valve), and replace.
	c) Transformer receptacle	1. Disconnected.	1. Connect.
	d) Operation switch	1. OFF position.	1. Move to ON position.
		2. Bad contacts.	2. Check for continuity and replace.
	e) Transformer	1. Coil winding opened.	1. Replace.
	f) Water valve	1. Coil winding opened.	1. Replace.
	g) Water supply tap	1. Closed.	1. Open.
		2. Water failure.	2. Wait till water is supplied.
h) Plug and receptacle (control box)	1. Disconnected.	1. Connect.	
	2. Terminal out of plug or receptacle.	2. Insert terminal back in position.	
i) Reed switch (spout)	1. Tripped.	1. See 1 - [3] - a).	
j) Overload protector	1. Tripped.	2. Reset.	
k) Model number	1. Incorrect.	2. Set correct number. See “III. 5. [b] SETTING MODEL NUMBER”.	
[2] Water does not stop, and the icemaker will not start.	a) Water control relay (controller board)	1. Contacts fused.	1. Replace controller board.
		2. Coil winding opened.	2. Replace controller board.
	b) Float switch	1. Bad contacts.	1. Check for continuity and replace.
		2. Float does not move freely.	2. Clean or replace.
	c) Flush water valve	1. Valve seat clogged and water leaking.	1. Clean or replace.
	d) Hoses	1. Disconnected.	1. Connect.
e) Mechanical seal	1. Water leaks.	1. Replace.	
f) Reservoir	1. Cracked.	1. Replace.	
[3] Water has been supplied, but the icemaker will not start.	a) Bin control	1. Bad contacts.	1. Check for continuity and replace.
	b) Gear motor protector (thermal breaker)	1. Tripped.	1. Find out the cause, resolve it, and press reset button on motor protector.
	c) Controller board	1. Defective.	1. Replace.

PROBLEM	POSSIBLE CAUSE		REMEDY
[3] (Continued)	d) Pressure switch, condenser thermistor	1. Dirty condenser fins.	1. Clean.
		2. Ambient temperature too warm.	2. Check for recommended temperature.
		3. Fan not rotating.	3. Replace.
		4. Condenser water pressure too low or off.	4. Check and get recommended pressure.
		5. Water regulating valve clogged.	5. Clean.
		6. Refrigerant overcharged.	6. Recharge.
		7. Refrigerant line or components plugged.	7. Clean and replace drier.
		8. Bad contacts.	8. Check for continuity and replace.
		9. Loose connections.	9. Tighten.
	e) Thermostat (water-cooled model)	1. Ambient temperature too warm.	1. Check for recommended temperature.
		2. Compressor cooling fan motor defective.	2. Replace.
		3. Bad contacts.	3. Check for continuity and replace.
		4. Loose connections.	4. Tighten.
f) Gear motor protect relay	1. Coil winding opened.	1. Replace.	
	2. Bad contacts.	2. Check for continuity and replace.	
[4] Gear motor starts, but compressor will not start or operates intermittently.	a) X4 relay (controller board)	1. Bad contacts.	1. Check for continuity and replace controller board.
		2. Coil winding opened.	2. Replace controller board.
	b) X6 relay	1. Bad contacts.	1. Check for continuity and replace X6 relay.
		2. Coil winding opened.	2. Replace X6 relay.
	b) Compressor	1. Loose connections.	1. Tighten.
		2. Motor winding opened or earthed.	2. Replace.
		3. Motor protector tripped.	3. Find out the cause of overheat or overcurrent.
	c) Power supply	1. Circuit ampacity too low.	1. Install a larger-sized conductor.
	d) Controller board	1. Defective.	1. Replace
	e) Start capacitor or run capacitor	1. Defective.	1. Replace
[5] Gear motor and compressor start, but no ice is produced.	a) Refrigerant line	1. Gas leaks.	1. Check for leaks with a leak detector. Reweld leak, replace drier and charge with refrigerant. The amount of refrigerant is marked on nameplate or label.
		2. Refrigerant line clogged.	2. Replace the clogged component.

2. LOW ICE PRODUCTION

PROBLEM	POSSIBLE CAUSE		REMEDY
[1] Low ice production	a) Refrigerant line	1. Gas leaks.	1. See 1 - [5] - a).
		2. Refrigerant line clogged.	2. Replace the clogged component.
		3. Overcharged.	3. Recharge.
	b) High-side pressure too high	1. Dirty air filter or condenser.	1. Clean.
		2. Ambient or condenser water temperature too warm.	2. Check for recommended temperature.
		3. Condenser water pressure too low or off.	3. Check and get recommended pressure.
		4. Fan rotating too slow.	4. Replace.
		5. Water regulating valve clogged.	5. Clean.
		6. Bad ventilation.	6. Remove anything blocking vents.
		7. Less than specified clearance at rear, sides and top.	7. Allow proper clearance for ventilation.
c) Expansion valve (not adjustable)	1. Low-side pressure exceeding the limit.	1. Replace.	
d) Evaporator	1. Evaporator pipe crushed.	1. Replace.	

3. OTHERS

PROBLEM	POSSIBLE CAUSE		REMEDY
[1] Abnormal noise	a) Fan motor (condenser unit)	1. Bearing worn out.	1. Replace.
		2. Fan blade deformed.	2. Replace fan blade.
		3. Fan blade does not move freely.	3. Replace.
	b) Compressor	1. Bearings worn out, or cylinder valve defective.	1. Replace.
		2. Mounting pad out of position.	2. Reinstall.
	c) Refrigerant lines	1. Rub or touch lines or other surfaces.	1. Replace.
	d) Gear motor (ice making)	1. Bearing or gear wear/damage.	1. Replace.
	e) Evaporator	1. Low-side pressure too low.	1. See if expansion valve bulb is mounted properly, and replace the valve if necessary.
		2. Scale on inside wall of freezing cylinder.	2. Remove auger. Use a solution of lime removing cleaner to clean periodically. If water is found to surpass the following levels, install a conditioner. Hardness 50 ppm Silica 30 ppm
	f) Heater	1. Defective.	1. Replace.
	g) CPR (condenser unit)	1. Internal leaks.	1. Replace.

PROBLEM	POSSIBLE CAUSE		REMEDY
[2] Overflow from reservoir (Water does not stop.)	a) Water supply	1. Water pressure too high.	1. Install a pressure reducing valve.
	b) Water valve	1. Diaphragm does not close.	1. Clean or replace.
	c) Float switch	1. Bad contacts.	1. Check for continuity and replace.
[3] Gear motor protector operates frequently.	a) Power supply voltage	1. Too high or too low.	1. Connect the unit to a power supply of proper voltage.
	b) Evaporator assy	1. Bearings or auger worn out.	1. Replace bearing or auger.

V. REMOVAL AND REPLACEMENT OF COMPONENTS

1. REFRIGERATION CIRCUIT

WARNING

This machine contains flammable refrigerant. Do not attempt to break into the refrigerant circuit unless qualified, competent and authorised to do so.

If any component of the refrigeration circuit requires removal or replacement, please contact the manufacturer:

HOSHIZAKI EUROPE LIMITED

Telford 70 Stafford Park 7, Telford, Shropshire TF3 3BQ UK

Tel: +44 (0)1952-291777

Fax: +44 (0)1952-292777

[a] APPLICABLE PARTS

Refrigerant (R290)

Compressor

Evaporator Casing

Air-cooled Condenser

Drier

Thermal Expansion Valve (with MOP)

2. EVAPORATOR ASSEMBLY

See the exploded view under “III. 3. ICEMAKING MECHANISM”.

- 1) Push the stop button to drain the water in the evaporator.
- 2) Disconnect the power source.
- 3) Remove the panels.
- 4) Remove the three thumbscrews, and take off the spout from the evaporator.
- 5) Remove the bin control switch.
- 6) Remove the spout gasket at the top of the evaporator.

CUTTER

- 7) Remove the bolt and lift off the cutter.

BELT HEATER

- 8) Detach the spring, and remove the belt heater.

EXTRUDING HEAD

- 9) Remove the sealing bolts, and lift off the extruding head.
- 10) Check the bearing inside the extruding head. If it is worn out or scratched, replace the bearing.

Note: Replacing the bearing needs a fitting tool. If it is not available, replace the whole extruding head.

AUGER

- 11) Lift out the auger. Check the top and bottom areas in contact with the bearings. If the surface is scratched or pitted, replace the auger. Check the blade edge of the auger. If it is scratched or worn where it has contacted the evaporator, replace it.

EVAPORATOR

If the evaporator requires removal or replacement, please contact the manufacturer.

HOUSING AND MECHANICAL SEAL

- 12) The mechanical seal consists of two parts. One part rotates with the auger, the other is static and is fitted into a top recess in the housing. If the contact surfaces of these two parts become worn or scratched, the mechanical seal may leak water and should be replaced.
- 13) Remove the O-ring on the top outer edge of the housing.
- 14) Remove the four bolts and lift the housing clear of the gear motor. Check the bearing inside the housing. If it is worn or scratched, replace it using a fitting tool. Carefully ease out the lower part of the mechanical seal before replacing the bearing.

Note: If a fitting tool is not available, replace the whole lower housing complete with bearing.

GEAR MOTOR

- 15) Cut the connectors.
- 16) Remove the three socket head cap screws securing the gear motor.
- 17) Assemble the removed parts in the reverse order of which they were removed.

WARNING

Be careful not to scratch the surface of the O-ring, or it may cause water leaks. Handle the mechanical seal with care not to scratch nor to contaminate its contact surface.

18) Refit the panels in their correct position.

19) Connect the power source.

3. CONTROL WATER VALVE

1) Disconnect the power source.

2) Close the water supply tap.

3) Remove the panels.

4) Disconnect the terminals from the control water valve.

5) Remove the cover - reservoir Inlet from the control water valve.

6) Loosen the fitting nut on the control water valve Inlets, and remove the control water valve. Do not lose the packings inside the fitting nut.

7) Install the new control water valve.

8) Assemble the removed parts in the reverse order of which they were removed.

9) Open the water supply tap.

10) Connect the power source.

11) Check for water leaks.

12) Refit the panels in their correct position.

4. FLUSH WATER VALVE

1) Push the stop button, and after 5 minutes disconnect the power source.

2) Close the water supply tap.

3) Remove the panels.

4) Remove the clamp and disconnect the hose from the flush water valve.

Note: Water may still remain inside the evaporator. Be sure to drain the water into the drain pan.

- 5) Disconnect the terminals from the flush water valve.
- 6) Remove the flush water valve from the bracket.
- 7) Remove the drain pipe from the flush water valve.
- 8) Connect the drain pipe to the new flush water valve, and place the valve in position.
- 9) Connect the hose to the flush water valve, and secure it with the clamp.
- 10) Pour water into the reservoir, and check for water leaks on the flush water valve.
- 11) Open the water supply tap.
- 12) Connect the power source.
- 13) Check for water leaks.
- 14) Push the stop button, and make sure water is flushing.
- 15) Push the ice button.
- 16) Refit the panels in their correct position.

5. CONTROLLER BOARD

IMPORTANT

A single type controller board is supplied as a service board. Some modifications and adjustment will be required to fit the icemaker models. Do not repair any parts and electronic devices on the controller board in the field. Replace the whole board with a new service board.

[a] MODIFICATION

- 1) Check that the service board package includes:
Controller board 1 pc. Instruction sheet 1 pc.
- 2) Modify the service board referring to the instruction sheet attached (Set the model number according to "III. 5. [b] SETTING MODEL NUMBER").

[b] REPLACEMENT

- 1) Disconnect the power source.
- 2) Remove the front panel.
- 3) Remove screws and the control box cover.

- 4) Disconnect the connectors and board support from the controller board.
- 5) Remove the controller board from the control box.
- 6) Install the new controller board and reassemble the control box in the reverse order of the removal procedure.
- 7) Replace the front panel in its correct position.
- 8) Connect the power source.